



User Maintenance Manual/Handbook

Issue 1.10

Software version 2.0.0+

Firmware version 2.0.0+

Isothermal Technology Limited, Pine Grove, Southport, PR9 9AG, England
Tel: +44 (0)1704 543830 Fax: +44 (0)1704 544799 Internet: www.isotech.co.uk E-mail:
info@isotech.co.uk

The company is always willing to give technical advice and assistance where appropriate. Equally, because of the programme of continual development and improvement we reserve the right to amend or alter characteristics and design without prior notice. This publication is for information only.

Contents

1	Introduction.....	5
1.1	Unpacking	5
1.2	Safety.....	5
2	Getting Started	8
2.1	A Quick Tour of Your milliK	9
2.2	Driving your milliK.....	11
2.2.1	The ‘Graph’ Window	12
2.2.2	The ‘Numeric’ Window	12
2.2.3	The ‘Settings’ Window	13
2.2.4	The ‘Instrument’ Window.....	15
2.3	Battery Operation	17
3	Detailed Description by Function	18
3.1	Using a PRT/SPRT with milliK.....	18
3.1.1	Configuring milliK to measure a PRT/SPRT	19
3.1.2	Determining Self-Heating of a PRT/SPRT.....	21
3.1.3	Using 3 or 4 Wire Measurement.....	21
3.2	Using a Thermistor with milliK	23
3.2.1	Configuring milliK to Measure Temperature with a Thermistor.....	24
3.3	Using a Thermocouple with milliK.....	25
3.3.1	Using Internal Reference Junction Compensation.....	26
3.3.2	Using External Reference Junction Compensation.....	26
3.3.3	Using an Ice-Point for the Reference Junction	27
3.3.4	Configuring milliK to Measure a Thermocouple.....	28
3.4	Using a 4-20mA Transmitter with milliK.....	30
3.4.1	Configuring milliK to Measure a 4-20mA Transmitter.....	31
3.5	Measuring the Difference Between Two Channels.....	32
3.6	Changing Graph Scales	32
3.7	Using Rolling Statistics.....	33
3.8	Logging Results to a File	34
3.8.1	Transferring Logged Data to a PC	36
3.8.2	File Format for Logged Data	36
3.8.3	Clearing Logged Data from Internal Memory	37
3.9	Using the Thermometer Database	38
3.9.1	Creating a New Thermometer Entry.....	38
3.9.2	Using a PRT with IEC60751 (2008) Conversion	40
3.9.3	Using a PRT with Callendar Van Dusen Conversion.....	41
3.9.4	Using a PRT with ITS90 Conversion	42
3.9.5	Using a Thermocouple with Calibration Coefficients / Data Pairs.....	43
3.9.6	Using a Thermistor with the Steinhart-Hart Polynomial	44
3.9.7	Using a Thermistor with Polynomial Temperature Conversion	45
3.9.8	Using a 4-20mA Transmitter with Linear Conversion	46
3.10	Updating the Software	47
3.11	Using and Changing Passwords	47
3.11.1	Recovering a Lost Password.....	49
3.12	Controlling Temperature Sources with milliK	49
3.12.1	Creating a Temperature Profile.....	51
4	Connecting Thermometers to milliK	53
4.1	Connecting PRTs/SPRTs to milliK.....	53
4.2	Connecting Thermistors to milliK.....	54

4.3	Connecting Thermocouples to milliK.....	55
4.4	Connecting 4-20mA Transmitters to milliK	56
5	Calibration.....	57
5.1	Standards Required for Calibration.....	58
5.1.1	Making a 4-Terminal Short-Circuit	58
5.1.2	Making a 0mV Source in a Thermocouple Connector	59
5.2	Checking the Calibration.....	59
5.2.1	PRT/SPRT Resistance Range	60
5.2.2	Thermistor Resistance Range (500kΩ) – Span Check	61
5.2.3	Thermocouple Voltage Range – Zero Check.....	62
5.2.4	Thermocouple Voltage Range – Span Check	63
5.2.5	4-20mA Transmitter Range – Zero and Span Check.....	63
5.2.6	Reference Junction Compensation Accuracy	64
5.3	Adjusting the Calibration	66
5.3.1	Starting the Calibration Adjustment Feature	66
5.3.2	Adjusting SPRT (115Ω) Resistance Range	67
5.3.3	Adjusting PRT (460Ω) Resistance Range	68
5.3.4	Adjusting Thermistor (500kΩ) Resistance Range.....	68
5.3.5	Adjusting Zero Voltage Offsets	69
5.3.6	Adjusting Voltage Gain	69
5.3.7	Adjusting 4-20mA Transmitter Range.....	70
5.3.8	Adjusting the RJC Sensor Calibration	71
5.4	Exporting Calibration information	72
6	Maintenance and Cleaning.....	73
7	Interfacing with milliK	74
7.1	RS232 Interface.....	74
7.1.1	Establishing an RS232 Connection.....	75
7.2	Ethernet Interface	76
8	SCPI Command Set	79
8.1	Command Terminators.....	79
8.2	SCPI Command Structure	79
8.3	SCPI Numeric Suffices	80
8.4	Parameters	80
8.5	Units	81
8.6	Making Measurement Using SCPI Commands	81
8.6.1	Measuring Resistance using SCPI Commands	82
8.6.2	Measuring Voltage using SCPI Commands	82
8.6.3	Measuring Temperature using SCPI Commands.....	83
8.6.4	SCPI Commands	85
8.6.5	Command: *IDN?.....	86
8.6.6	Command SENSE:FUNcTION[:ON].....	86
8.6.7	Command SENSE:FUNcTION[:ON]?.....	86
8.6.8	Command SENSE:CHANnel	86
8.6.9	Command SENSE:CHANnel?	87
8.6.10	Command SENSE[:RESistance]:RANGe[:UPPer].....	87
8.6.11	Command SENSE[:RESistance:]RANGe[:UPPer]?.....	87
8.6.12	Command SENSE:RESistance:WIREs.....	88
8.6.13	Command SENSE:RESistance:WIREs?.....	88
8.6.14	Command SENSE:CURREnt	88
8.6.15	Command SENSE:CURREnt?.....	89

8.6.16	Command INITiate[:IMMediate][:ALL].....	89
8.6.17	Command FETCh[:SCALar]?	89
8.6.18	Command READ[:SCALar]?	89
8.6.19	Command MEASure[:SCALar]:VOLTage[:DC]<channel#>?	89
8.6.20	Command MEASure[:SCALar]:RESistance<channel#>	90
8.6.21	Command MEASure[:SCALar]:CURRent?.....	90
8.6.22	Command MEASure[:SCALar]:RJC?.....	90
8.6.23	Command MONitor<channel#>?	91
8.6.24	Command CALibrate:UNLock.....	91
8.6.25	Command CALibrate:LOCK.....	91
8.6.26	Command CALibrate:RESistance:GAIN	92
8.6.27	Command CALibrate:RESistance:GAIN?	92
8.6.28	Command CALibrate:VOLTage:OFFSet<channel#>.....	92
8.6.29	Command CALibrate:VOLTage:OFFset<channel#>?.....	93
8.6.30	Command CALibrate:VOLTage:GAIN	93
8.6.31	Command CALibrate:VOLTage:GAIN?.....	93
8.6.32	Command CALibrate:CURRent:GAIN.....	94
8.6.33	Command CALibrate:CURRent:GAIN?.....	94
8.6.34	Command CALibrate:RJC:OFFSet	94
8.6.35	Command CALibrate:RJC:OFFSet?	95
8.6.36	Command CALibrate:IDENtification.....	95
8.6.37	Command CALibrate:IDENtification?.....	95
8.6.38	Command CALibrate:IDENtification:LAST?.....	95
8.6.39	Command CALibrate:PASSword.....	96
8.6.40	Command CALibrate:VALid?.....	96
9	Specification	97
10	Approvals.....	100
10.1	CE Declaration	100
10.2	FCC Statement.....	100
10.3	Standards Applied.....	101
11	Revision History	102

1 Introduction

The milliK precision thermometer provides a complete measurement and control interface for users wishing to make high accuracy temperature measurements or calibrate thermometers. It supports a wide range of thermometer types including 25 Ω SPRTs, 100 Ω PRTs, thermistors, thermocouples and 4-20mA transmitters (self-powered and loop-powered) and can control Isotech temperature sources, sequencing through a programmable list of temperature set points whilst logging data to internal memory or a USB drive.

The milliK sets new measurement standards in its class ($<\pm 5$ ppm for SPRTs/PRTs, $<\pm 2$ μ V for thermocouples and $<\pm 1$ μ A for current transmitters). The Windows™ CE operating system provides a simple and intuitive operator interface and with a wide range of interfaces (USB, RS232, Ethernet) allows the user to access the comprehensive features of the milliK.

1.1 Unpacking

Your product should comprise the following items:

- ‡ milliK Precision Thermometer
- ‡ power supply with interchangeable plug heads
- ‡ two Lemo 6-pin connectors
- ‡ null modem RS232 cable
- ‡ this user manual

If any item is missing or damaged, please report this immediately to your supplier. If possible, we recommend that you retain the packaging material in case you need to return the instrument for calibration or service.

1.2 Safety

The milliK is a precision instrument, designed for use in a laboratory or light industrial environment. It complies with the requirements of safety standard EN61010-1 (2001) and is therefore safe to use in laboratory or light industrial environments. It is not intended for use outdoors or in extreme environments (refer to specification in Section 9).



The milliK is likely to be connected to thermometer sensors in use and the operator should take care to ensure that the complete system is safe. For example, metal sheathed thermometers may be connected to the milliK and then placed in a furnace powered from a 230V electrical supply. Single fault conditions in such a furnace could lead to the thermometer wires and the front terminals of the milliK to which they are connected becoming electrically live and therefore a hazard to the operator. Suitable precautions should be taken, such as using an isolating transformer in the supply to such a furnace. If you require further advice on safety issues, please contact Isothermal Technology or one of our appointed distributors - we have extensive experience of thermometry and can provide advice and equipment to help you.

Retain these instructions. Use only as specified in these operating instructions or the intrinsic protection may be impaired.

Please observe the following safety precautions:

- ⌚ Do not use your milliK if it is damaged
- ⌚ Only connect the power supply to an electrical supply that conforms to the specification given on its rating plate
- ⌚ This equipment is for indoor use within an ambient temperature range of 0°C to 40°C with maximum relative humidity of 95%
- ⌚ This equipment is for use in moderate climates only. NEVER use the equipment in damp or wet conditions
- ⌚ Avoid excessive heat, humidity, dust & vibration
- ⌚ Do not place liquid filled containers on the equipment
- ⌚ Do not use where the equipment (or any associated accessories) may be subjected to dripping or splashing liquids
- ⌚ Ensure all cables and wires are routed safely to avoid tripping: also to avoid sharp bends and pinches
- ⌚ Clean only with a damp cloth. Do not wet or allow moisture to penetrate the equipment. Do not use solvents; see section 6 for details of cleaning procedure
- ⌚ The product should be subjected to regular in-service inspections as required by local regulations; a yearly interval is suggested
- ⌚ Do not apply earth test currents to any terminals nor to the shrouds of the USB, RS232, or Ethernet connectors
- ⌚ The product is designed to comply with EN 61010-1 and can be flash tested. It is fitted with radio frequency interference suppressors. Therefore it is recommended that only a D.C. test be performed. Performing flash tests repeatedly can damage insulation
- ⌚ This equipment contains no user-serviceable parts. Refer all repairs to qualified service personnel. Contact Isothermal Technology or one of our appointed distributors for details of approved service outlets
- ⌚ The power supply has been approved to the following safety standards:

UL60950-1, 2nd Edition: 2007-03-27

CSA C22.2 No. 60950-1-07, 2nd Edition: 2007-03

EN 60950-1: 2006 including A11

BS EN60950-1: 2006

AS/NZS60950-1: 2003 including amendments 1, 2 and 3

2 Getting Started

The power supply operates from any standard AC electrical supply (90-264V RMS at 47-63Hz), so unless your supply is unusual you can simply connect the power supply to a suitable electrical outlet.

The power supply is fitted with a standard BS 1363 plug head but is provided with alternative heads that cover the majority of electrical sockets used worldwide. If you need to connect to an outlet socket that is not supported by the plug heads provided you should source a suitable electrical supply lead locally that is fitted with a C8 connector, you can then plug this directly into the C8 socket on the power supply. The plug head can easily be changed:

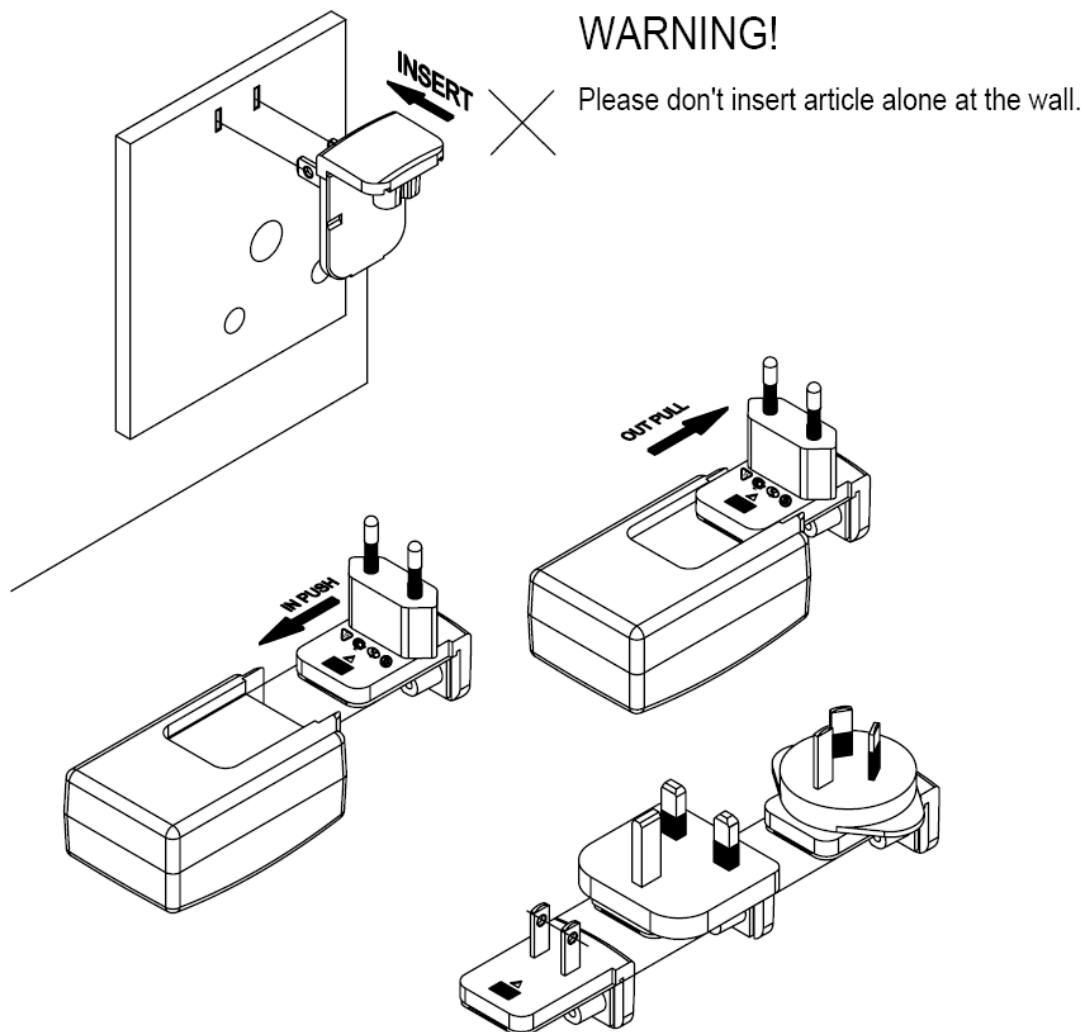



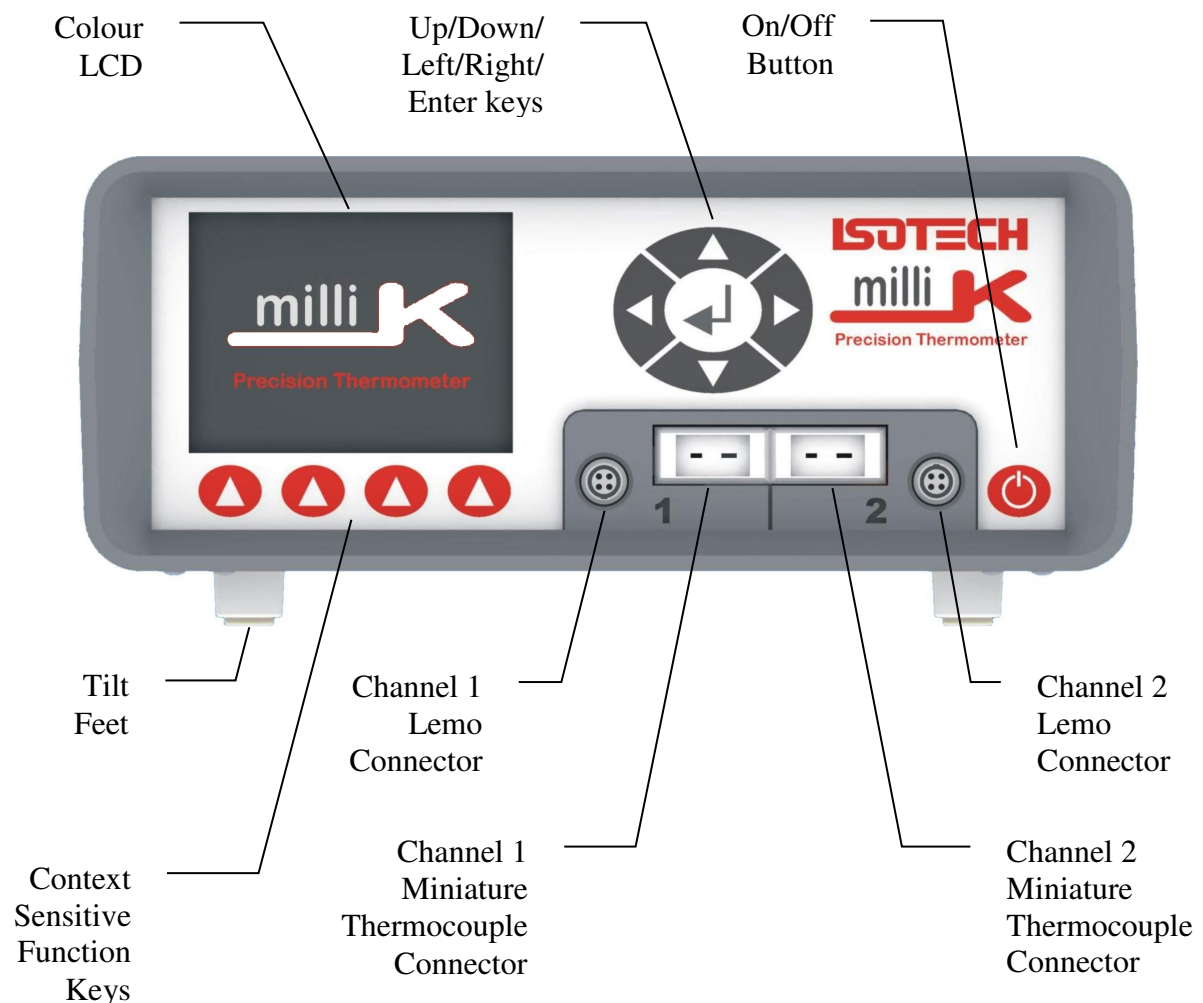

Plug the DC connector from the power supply into the “DC Power” socket on the rear of the milliK. Press the on/off button on the front panel to turn on your milliK. The milliK will load the operating system and software (15s) and then restore itself to the settings used when it was de-powered. This manual provides comprehensive details on using your milliK, in addition video tutorials are available on the Isotech website (see www.isotech.co.uk/video-library.php).

2.1 A Quick Tour of Your milliK

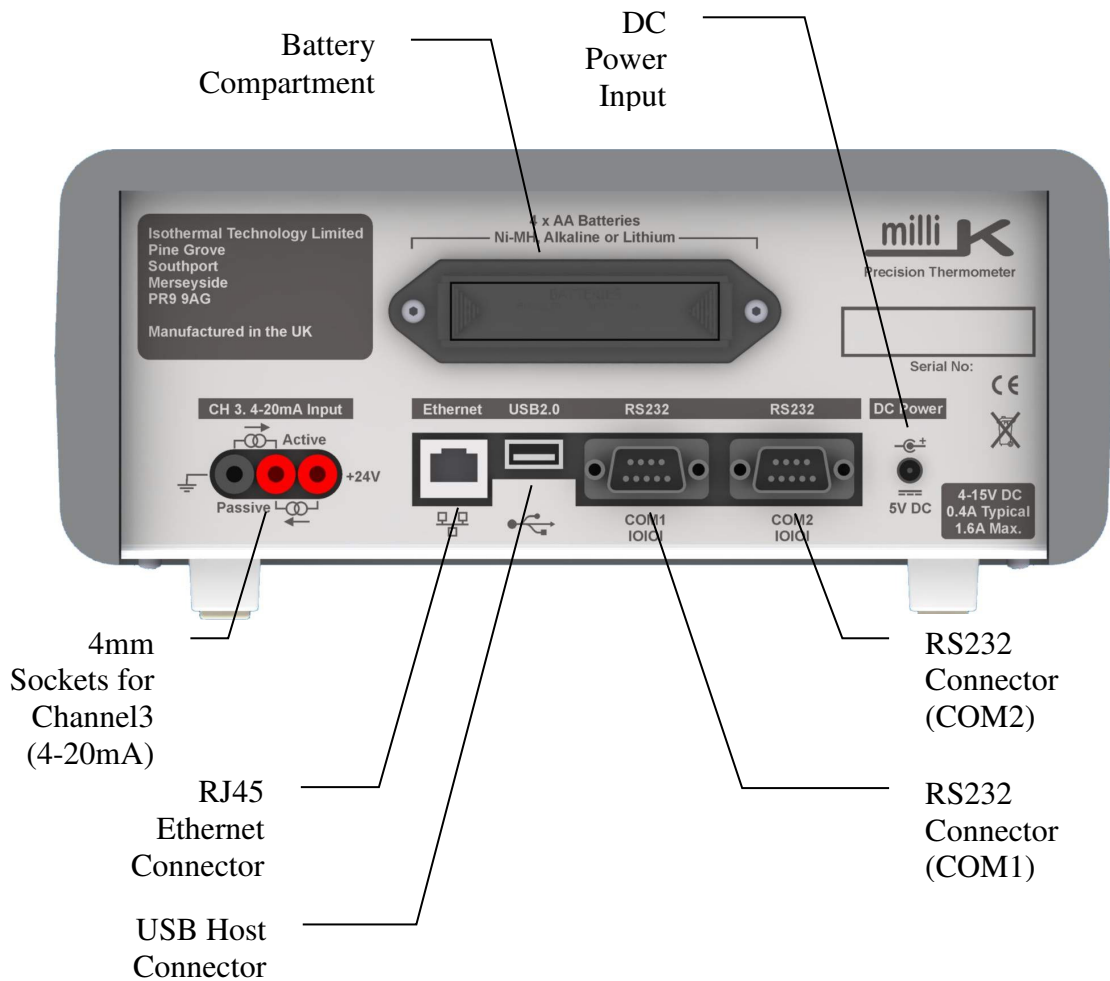
On the front of your milliK you will find two sets of connectors (Lemo 6-pin circular connectors for SPRTs/PRTs/thermistors and miniature thermocouple connectors) for channels 1 and 2. On the rear of your milliK you will find the 4mm sockets for channel 3 (used exclusively for 4-20mA transmitters).



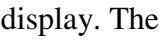

The milliK is controlled using the  (left/right/up/down/enter) key cluster and the 4 function keys located below the display. The  keys are used to navigate between items on the screen and the  key is used to select or toggle the highlighted item. The function keys select the context sensitive function displayed above each key. The milliK will display soft keyboards when required so that all features of the milliK can be accessed using these keys. You can also connect a keyboard and/or mouse to the USB port (rear panel) and use these to control the milliK. The function keys below the display are mapped to keys F1-F4 on the keyboard.

The milliK is also equipped with two RS232 ports (these are completely interchangeable), a USB 2.0 host port and Ethernet port (10/100MBit), available on the rear panel. The milliK is primarily for use as a bench-top laboratory standard but can also be powered from 4 x AA cells (Ni-MH, Alkaline or Lithium) if a suitable electrical supply is not available (typical rechargeable Ni-MH cells provide > 4 hours operating life). The battery compartment is located on the rear panel.

2.2 Driving your milliK

When the milliK is turned on, the opening Window appears showing the configuration:

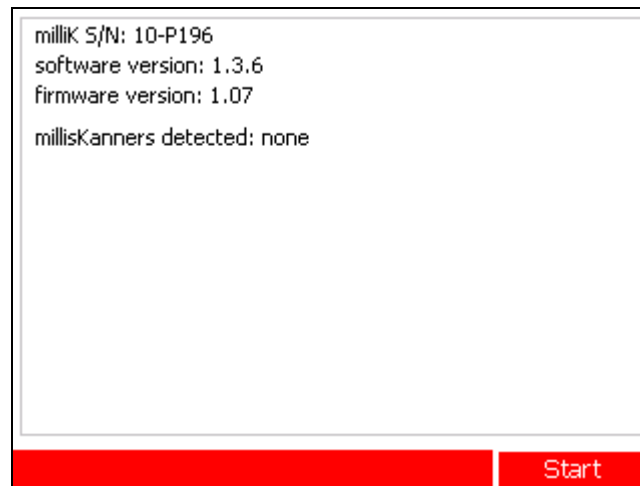

Press the right-hand function key below **Start** to proceed (or connect a USB keyboard or mouse and press F4 or click **Start**). The milliK software will then start and you will see the main Windows:

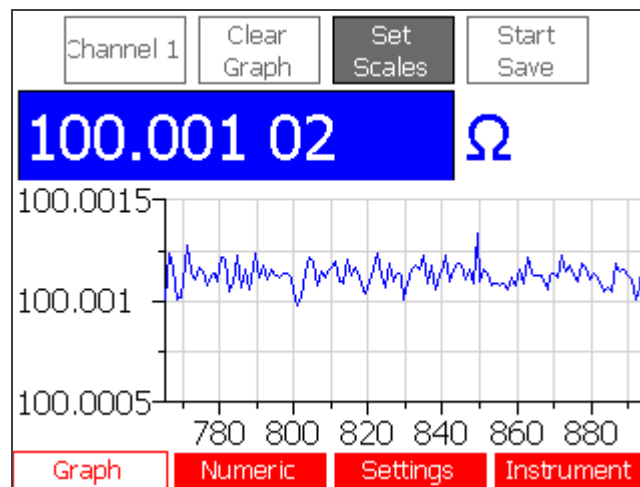

There are four main Windows, which can be selected using the function keys below the display. The software always starts with the **Graph** Window selected as shown above.

We will now provide a description of each Window. If you wish to perform a particular function (for example changing the time/date) then you can find help on this by locating it in the table of contents at the start of this manual and going straight to the relevant section.

2.2.1 The 'Graph' Window

In the **Graph** window you can view a single channel (or the difference between any channel and Channel 1) in graphical and numerical form. Functions available from within this Window are:

- ⌵ Select which channel (or the difference between which channel and channel 1) to view
- ⌵ Clear the graph
- ⌵ Set the scales for the graph (automatic scaling available for vertical axis)
- ⌵ Start/stop logging of data to internal or external (USB drive) memory

Use the **←→** keys to select from the buttons displayed at the top of the screen and press the **↓** key to activate that function (for example, to clear the statistics). To change which channel is displayed (or to select a difference) use the **←→** keys to select the right-hand button and either use the **↑↓** keys to sequence through the channels or press the **↓** key to open a Window containing a list of all the available channels. Only channels that are enabled (in the 'Settings' Window) appear, so if only one channel is enabled this button has no effect.

2.2.2 The 'Numeric' Window

In the **Numeric** window you can view enabled channels in numeric form, together with their mean and standard deviations. Channels that are not enabled in the **Settings** Window do not appear. You can choose whether to view a single channel with a large font or all the channels with a smaller font using the **Single Channel** / **All Channels** button. If you choose to view a single channel then the base units for the thermometer will be displayed at the same time:

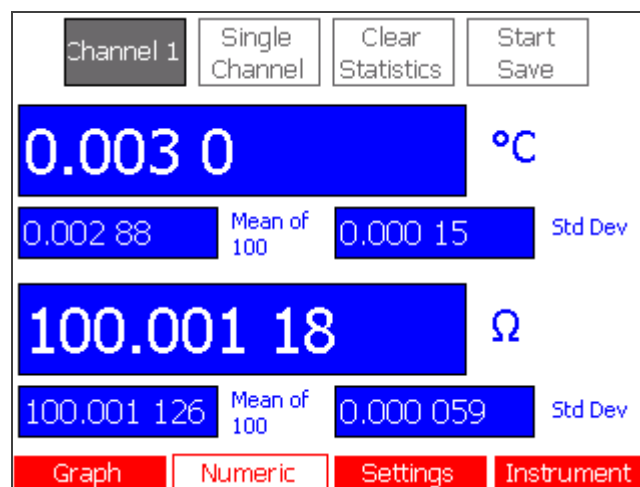

Channel 1		All Channels	Clear Statistics	Start Save
Ch	Value	Units	Mean	Std Dev
1	0.002 6	°C	0.002 85	0.000 15
2	-0.005 4	°C	-0.005 01	0.000 28
2-1	-0.007 9	°C	-0.008 05	0.000 21

Graph Numeric Settings Instrument

Functions available from within this Window are:

- ⏏ Select which channel (or the difference between which channel and channel 1) to view
- ⏏ Select whether to display a single channel or all channels
- ⏏ Clear the rolling statistics and reset the statistics counter
- ⏏ Start/stop logging of data to internal or external (USB drive) memory

Use the ← → keys to select from the buttons displayed at the top of the screen and press the ⏏ key to activate that function (for example, to clear the statistics).

2.2.3 The ‘Settings’ Window

In the ‘Settings’ window you can change the settings for each measurement channel.

Channel	Channel 1
Status	Enabled
Thermometer	Default 4-Wire PRT
Type	PRT
Conversion	IEC60751 (2008)
Range	460Ω
Units	°C
Current	1mA
Samples/Reading	1
Readings in Stats	100

Graph Numeric Settings Instrument

Use the ↑ ↓ keys to select the setting you wish to change and then use the ← → keys to change it to the required value. If a channel is not being used, it is best to change its ‘Status’ to “Disabled” as this will then make the measurement time available to other enabled channels, which will speed up these measurements. The ‘Type’ field is for information

purposes only and cannot be changed. Pressing the key when the ‘Thermometer’ setting is selected opens a Window with a list of all thermometers in the milliK’s database:

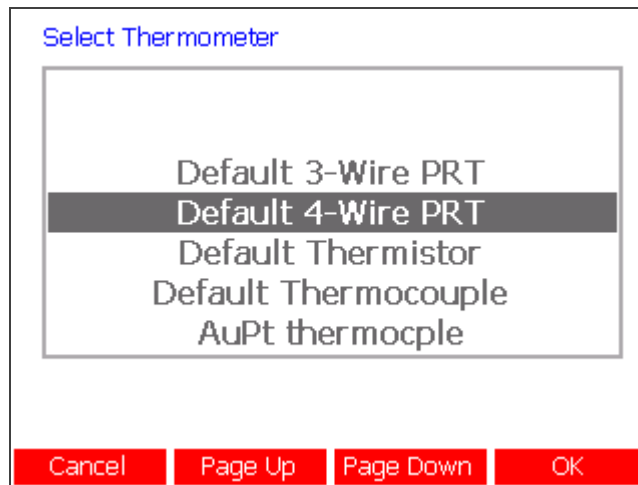

Use the keys to highlight the required thermometer and press the **OK** (F4) key to select it. The **Page Up**/**Page Down** (F2/F3) keys below the display provide easy navigation if a large number of thermometers has been created.

Press the key when the ‘Samples/Reading’ or ‘Readings in Stats’ settings are selected to open a numeric entry window and specify a value. This may be quicker than using the keys to change the value:

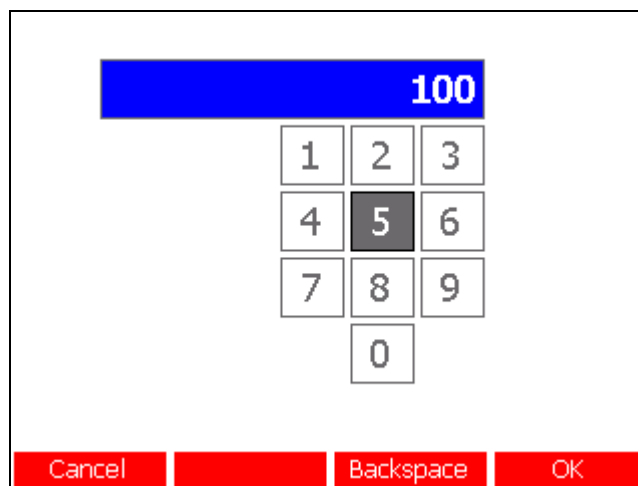

Use the keys to move to a number button and select it using the key. As soon as you start entering a new number, the original value is deleted. Press the **OK** (F4) key to apply the new value.

The 'Samples/Reading' setting is initially set to 1 but can be increased to a maximum of 100. This will cause the milliK to take the specified number of samples for each reading and will reduce the noise at the expense of slower measurement speed.





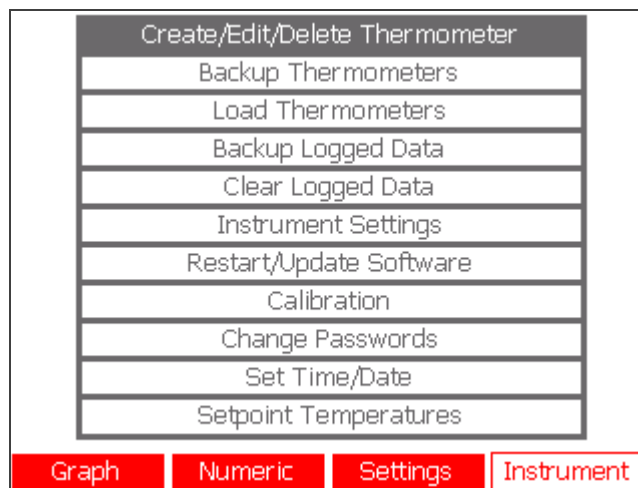

2.2.4 The 'Instrument' Window

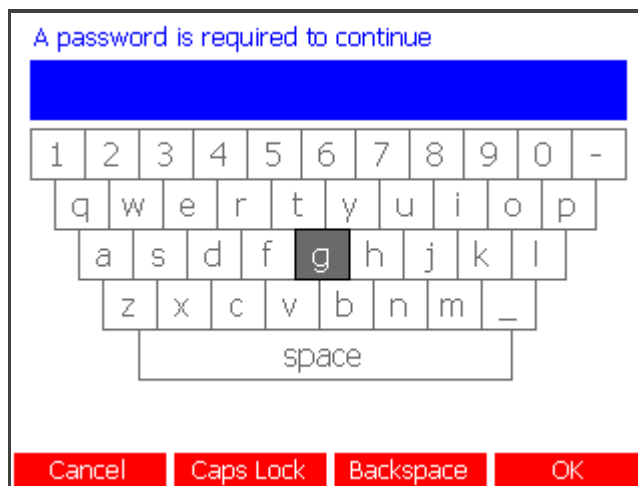
In the 'Instrument' Window you can access the milliK's database of thermometers, perform maintenance tasks (such as backing up, clearing or restoring information stored to internal memory, updating software, calibrating your milliK), change the IP address/passwords/date/time settings and define temperature profiles you wish to use when calibrating thermometers with your Isotech temperature source:



Use the **↑****↓** keys to select the required function and then press the **↵** key to open a new Window to access that function. Some functions are password protected, in which case a soft keyboard will appear and you will be asked to enter the password before proceeding:



Use the     keys to move to a button and select it using the  key. Press  to enter the password. A separate password is provided to protect the calibration of the milliK. Both passwords are initially set to “1234” but should be changed prior to use in order to ensure the security of measurements made using your milliK (see section 3.11). A password recovery process is available if you forget your password, please contact Isothermal Technology or its approved distributor for assistance if required (see section 3.11.1).

2.3 Battery Operation

The milliK is primarily intended for use as an AC powered, bench-top instrument and is supplied with a universal power supply for this purpose. However, it may also be powered from batteries (not supplied) so that it can be used where an AC electrical supply is not available.

The battery compartment is located on the rear panel. To gain access, squeeze the tabs on the sides of the battery draw and slide it out. The battery compartment accepts four AA size cells.

The milliK can use primary (alkaline or lithium) cells or rechargeable (NiMH) cells. Lithium cells provide the longest battery life (>6 hours), but are expensive and are not rechargeable. Rechargeable NiMH cells provide good battery life (> 4 hours) and being rechargeable offer low running costs, they are therefore the recommended solution for users wishing to use battery powered operation. Alkaline cells can be used, but they provide limited operating life; tests have shown that alkaline cells offer half the operating life of NiMH cells with the same quoted capacity (mAh) because they have a higher output impedance during discharge (leading to a lower output voltage).

3 Detailed Description by Function

This section describes all the features available on the milliK by function. If you wish to learn how to do something with your milliK use the table of contents on page 2 onwards to look up the appropriate section.

3.1 Using a PRT/SPRT with milliK

The milliK can measure the resistance of PRTs and SPRTs. It can convert measurements from resistance to temperature units (K, °C or °F) so that you can make precise temperature measurements or calibrate other thermometers from a reference standard.

The milliK provides two resistance measurement ranges which are optimised for PRTs and SPRTs:

- 0-115Ω: optimised for 25.5Ω SPRTs
- 0-460Ω: optimised for 100Ω PRTS

The milliK will measure 25.5Ω SPRTs on the 460Ω range, but better measurement uncertainty is achieved by using the 115Ω range. The sense current for both ranges is 1mA (or 1.428mA).

Connect your PRTs/SPRTs to either of the Lemo 6-pin circular connectors on the front panel (see section 4.1 for pin-out and connection details). Ensure that the miniature thermocouple connector for the same channel is unused (since it is connected in parallel with the Lemo connector). Isotech can (optionally) supply thermometers fitted with a suitable Lemo connector. Your milliK is supplied with two Lemo connectors for you to use with your own PRT/SPRT (or thermistor). The part number for this connector is:

Lemo part number: FGG.1B.306.CLAD62Z

Additional connectors are readily available internationally from Farnell Electronics and can be ordered via their website www.farnell.com (Farnell stock code 3817325).

Channels 1 and 2 are not isolated from each other, but are isolated from Channel 3 and from the digital interfaces in order to optimise immunity to external noise sources.

3.1.1 Configuring milliK to measure a PRT/SPRT

Press the **Settings** (F3) key to access the **Settings** Window, which opens with the ‘Channel’ parameter selected. Use the **←** **→** keys to select the channel that you want to configure. Then use the **↑** **↓** keys to select each parameter in turn and set it to the required value either by using the **←** **→** keys to sequence through the options or pressing the **↵** key to open a new Window with all the options listed. A typical configuration for an uncalibrated PRT would be:

Channel	Channel 1
Status	Enabled
Thermometer	Default 4-Wire PRT
Type	PRT
Conversion	IEC60751 (2008)
Range	460Ω
Units	°C
Current	1mA
Samples/Reading	1
Readings in Stats	100

Graph Numeric Settings Instrument

‘Range’ would normally be set to 460Ω for a 100Ω PRT and to 115 Ω for a 25.5 Ω SPRT (see section 3.1). Most PRT/SPRT measurements are made with a 1mA sense current, but this can be increased to 1.428mA in order to determine the self heating effect (see section 3.1.2). The ‘Samples/Reading’ setting is the number of samples averaged together to form a single reading. Increasing this value will reduce the noise on the measurements (standard deviation will reduce as the square root of the number of samples) but also slows down the update rate.

Higher accuracy measurements can be made using calibrated PRTs/SPRTs whose resistance-temperature characteristics have been determined. Before being used, the thermometer and its calibration details must be entered into the milliK’s thermometer database (see section 3.9.1). The thermometer will then appear in the ‘Thermometer’ list. Use the **←** **→** keys to sequence through the thermometers or press the **↵** key to open a new Window with all thermometers listed:

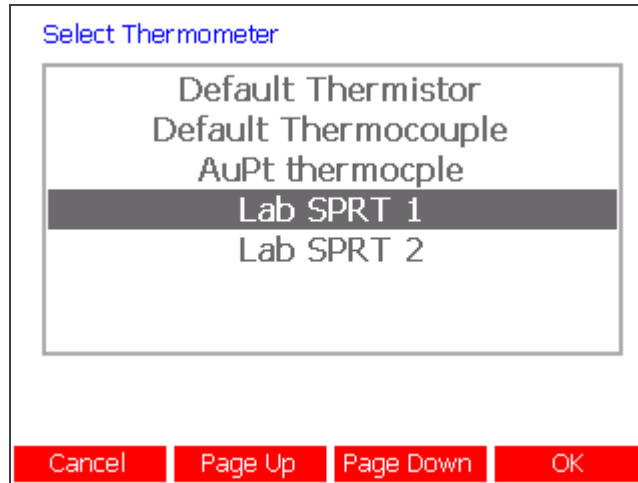

Select the thermometer and set the remaining parameters in the **Settings** Window. A typical configuration for a calibrated SPRT would be:

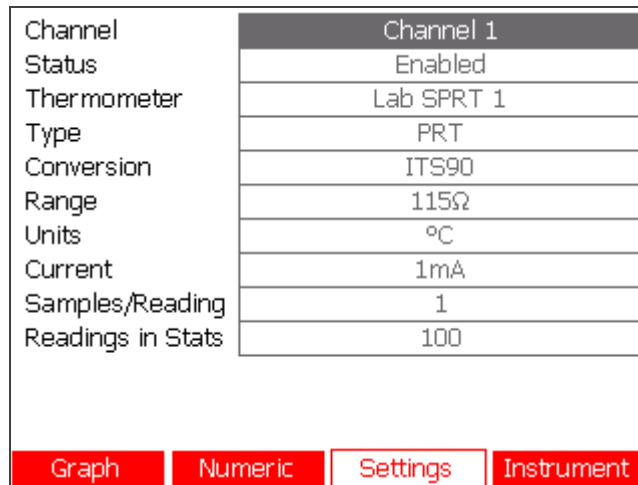

Once you have configured the milliK to work with your PRT/SPRT, press either the **Graph** (F1) or **Numeric** (F2) keys to view the measurements:

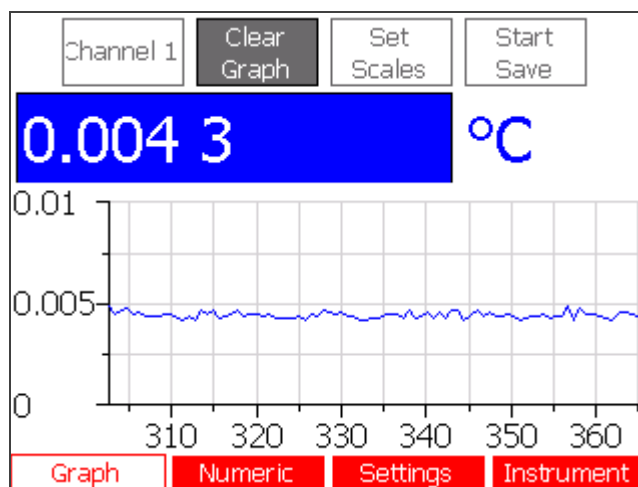

Use the  keys to navigate between and select the on-screen buttons to select the channel, clear the graph, clear the statistics (Numeric Window), set the scales or start/stop logging of data to a file.

3.1.2 Determining Self-Heating of a PRT/SPRT

The normal sense current used by the milliK for PRTs/SPRTs is 1mA. This current causes a small amount of self heating in the thermometer (typically 1 to 3mK). Provided that the thermometer is calibrated and used at the same current, this leads to negligible uncertainty in the measurement.

In some special applications the self heating effect is a significant source of measurement uncertainty and it may be necessary to determine the amount of self heating in the thermometer. This is easily achieved by varying the sense current and observing the change in indicated temperature. The milliK provides a feature that allows the sense current to be increased by a factor of 1.428 ($\approx \sqrt{2}$ mA), which increases the power dissipated by a factor of two (since power is proportional to current squared). The change in indicated reading caused by this change is then a direct measure of the self-heating effect at the normal 1mA sense current (if the self heating effect at 1mA is δT , then the self heating at $\sqrt{2}$ mA is $2\delta T$ and the difference between the two readings is $2\delta T - \delta T$ i.e. δT).

3.1.3 Using 3 or 4 Wire Measurement

The milliK uses a 4-wire connection technique to eliminate the effect of the cable resistance from the measurement. This involves supplying the sense current through one pair of wires and monitoring the voltage developed across the PRT element with a separate pair of wires:

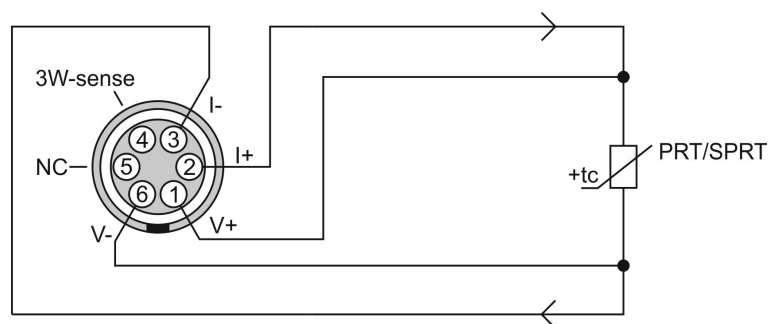

Since the current along the voltage sense wires is effectively zero, the milliK is able to measure the resistance of the PRT element without being affected by the resistance of the wires.

In some industrial applications a 3-wire connection technique is used in order to reduce the cost of cabling (important when a large number of PRTs and long cable runs are involved, such as in a petrochemical plant). In this arrangement, there is a separate current and voltage sense connection to one side of the PRT element, but the other side has a common connection:

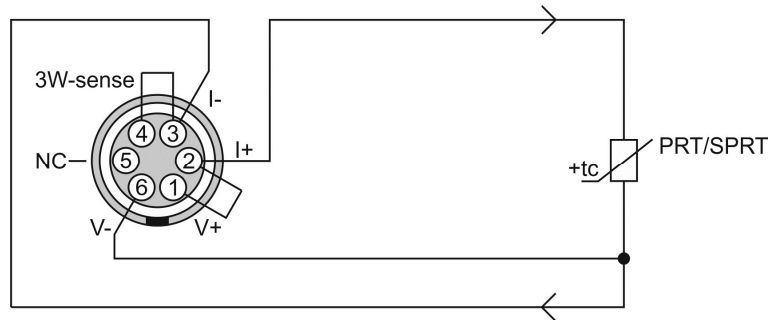

The milliK measures the voltage developed across the I- wire by measuring the voltage between pins 4 and 6. Provided the wires are all the same gauge and length (same resistance) the voltage drop down the I+ wire will be the same, so the milliK can subtract this correction from the voltage measured between V+ and V- (pins 1 and 6) to determine the voltage across the PRT element. In this way the milliK is able to perform a 3-wire measurement that is substantially immune to the resistance of the wires. The common and current leads should be cut to the same length and connected directly to pins 2 and 3 and a link wires (carrying no current) should be used to link pins 1 to 2 and pins 3 to 4 in order to minimise uncertainty due to the limitations of 3-wire measurement (inequalities in the wire resistance).

If you wish to make temporary connections to a 3-wire PRT using intermediate connectors (typically required for calibrating 3-wire PRTs), then you must ensure that the resistance in the extension connections to the I+ and I- wires is the same:

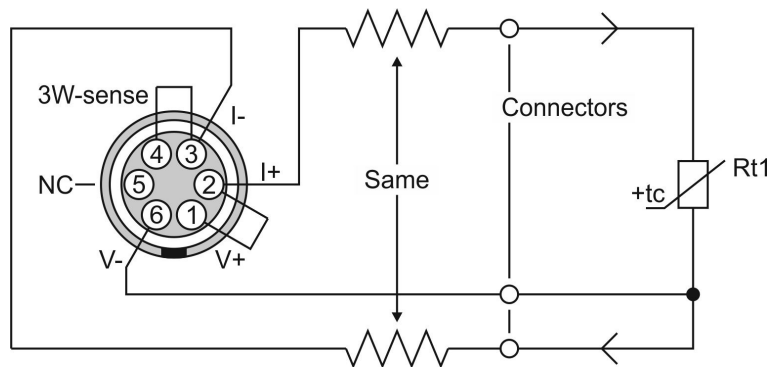

This can be achieved by using the same gauge and length of wire for the I+ and I- leads. Use the lowest resistance wire (that is mechanically suitable) so as to minimise the resistance of

the extension connections and therefore minimise any error from the imbalance in their resistance.

3.2 Using a Thermistor with milliK

The milliK can be used with resistance thermometers based on thermistors. These are typically NTC (negative temperature coefficient) devices which have well defined characteristics and can offer accuracies down to 25mK or less. Compared with PRTs/SPRTs, thermistors have a much higher resistance (typically measured in tens of k Ω), operate over a more limited temperature range (typically < 150°C) are highly non-linear, but they are lower cost and can be more robust. The non-linear resistance-temperature characteristics make thermistor sensors very sensitive over a limited temperature range. Their relatively high resistance means that 4-wire measurement is not as important as with PRTs/SPRTs (although the milliK still uses 4-wire measurement). However, their high resistance makes them more prone to electrical interference so greater care is required when connecting them to the milliK, in particular the use of screened cables is highly recommended (see section 4.2).

Unlike PRTs/SPRTs, the resistance-temperature characteristics vary considerably between different types of thermistor. There are, therefore, no nominal or generic conversion algorithms. The milliK can be used to monitor the resistance of a thermometer declared to be a Default Thermistor, but in order to measure temperature, the thermistor and its calibration details must be entered into the milliK's thermometer database.

Connect your thermistor to either of the Lemo 6-pin circular connectors on the front panel using a 2-wire or 4-wire connection arrangement (see section 4.2 for pin-out and connection details). Ensure that the miniature thermocouple connector for the same channel is unused (since it is connected in parallel with the Lemo connector). Your milliK is supplied with two Lemo connectors for you to use with thermistors. The part number for this connector is:

Lemo part number: FGG.1B.306.CLAD62Z

Additional connectors are readily available internationally from Farnell Electronics and can be ordered via their website www.farnell.com (Farnell stock code 3817325).

Channels 1 and 2 are not isolated from each other, but are isolated from Channel 3 and from the digital interfaces in order to optimise immunity to external noise sources.

3.2.1 Configuring milliK to Measure Temperature with a Thermistor

Firstly the thermistor and its calibration details must be entered into the milliK's thermometer database (see section 3.9.1), the thermistor will then appear in the 'Thermometer' list. Press the **Settings** (F3) key to access the **Settings** Window, which opens with the 'Channel' parameter selected. Use the **←** **→** keys to select the channel that you want to configure. Then use the **↑** **↓** keys to select each parameter in turn and set it to the required value either by using the **←** **→** keys to sequence through the options or pressing the **↵** key to open a new Window with all the options listed. A typical configuration for a thermistor would be:

Channel	Channel 1
Status	Enabled
Thermometer	Therm STHM100
Type	Thermistor
Conversion	Steinhart-Hart
Range	500k Ω
Units	$^{\circ}$ C
Current	2 μ A
Samples/Reading	1
Readings in Stats	100

Graph
Numeric
Settings
Instrument

The Samples/Reading parameter is the number of samples averaged together to form a single reading. Increasing this value will reduce the noise on the measurements (standard deviation will reduce as the square root of the number of samples) but also slow down the update rate.

The resistance of a thermistor can be measured without entering any calibration information by declaring the 'Thermometer' as a "Default Thermistor". This can be useful when calibrating thermistors against other thermometers:

Channel	Channel 1
Status	Enabled
Thermometer	Default Thermistor
Type	Thermistor
Conversion	None
Range	500k Ω
Units	Ω
Current	2 μ A
Samples/Reading	1
Readings in Stats	100

Graph Numeric Settings Instrument

Once you have configured the milliK to work with your thermistor, press either the **Graph** (F1) or **Numeric** (F2) keys to view the measurements:

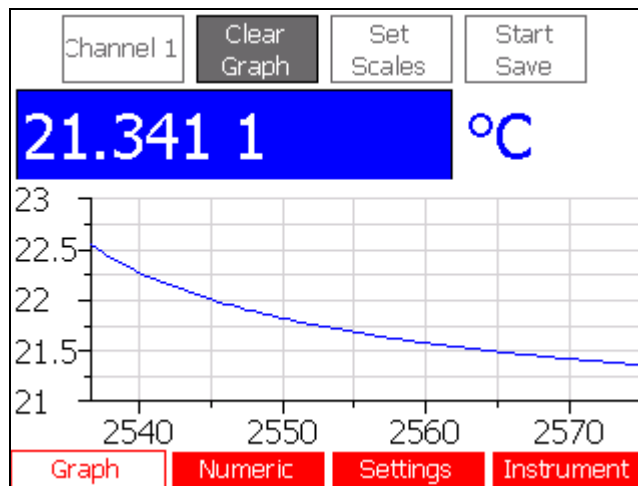

Use the **←** **→** **↑** **↓** **↵** keys to select and activate the on-screen buttons to clear the graph/statistics, set the scales and start/stop logging of data to a file.

3.3 Using a Thermocouple with milliK

The milliK can be used with any thermocouple (calibrated or uncalibrated) fitted with a standard miniature thermocouple connector. Connect your thermocouple to either of the miniature thermocouple connectors on the front panel. Ensure that the Lemo circular connector for the same channel is unused (since it is connected in parallel with the thermocouple connector). Isotech supply thermocouples fitted with standard miniature thermocouple connectors for direct connection to your milliK.

3.3.1 Using Internal Reference Junction Compensation

The EMF developed by a thermocouple depends on the temperature difference between the measurement and reference junctions. It is therefore necessary to know the temperature of the reference junction (the point at which the electrical circuit changes to copper) in order to calculate the temperature at the measurement junction. The milliK measures the temperature of the contacts in the miniature thermocouple connectors on the front panel so that these can be used as the reference junction in the thermocouple system. In this arrangement there is no externally accessible reference junction and wires that make up the thermocouple are connected to the milliK using a connector made of the same material as the wire itself. It is essential that the correct “typed” connector is used with the thermocouple:

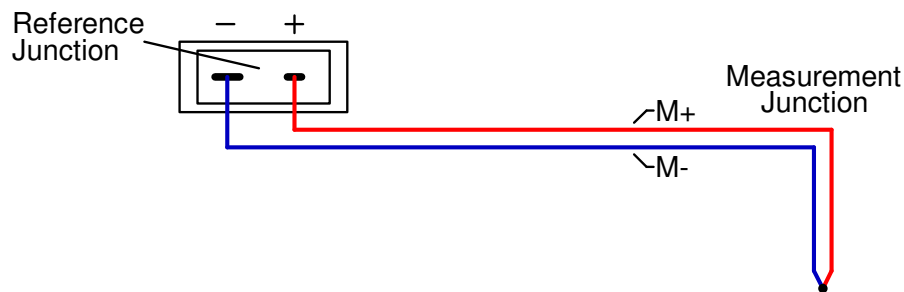

When using a thermocouple with internal reference junction compensation, the ‘Reference’ parameter in the **Settings** Window should be set to “Internal” (see section 3.3.4).

For greater accuracy, you can use an external reference junction whose temperature is measured with a calibrated thermometer (see section 3.3.2) or that is immersed in an ice-point at 0°C (see section 3.3.3).

3.3.2 Using External Reference Junction Compensation

The milliK allows you to measure the temperature of an external reference junction using a thermometer connected to another channel. This technique can provide better measurement uncertainty (than using internal reference junction compensation, see section 3.3.1) provided that the reference junction and sensing thermometer are adequately isothermal and that the reference junction thermometer is sufficiently accurate:

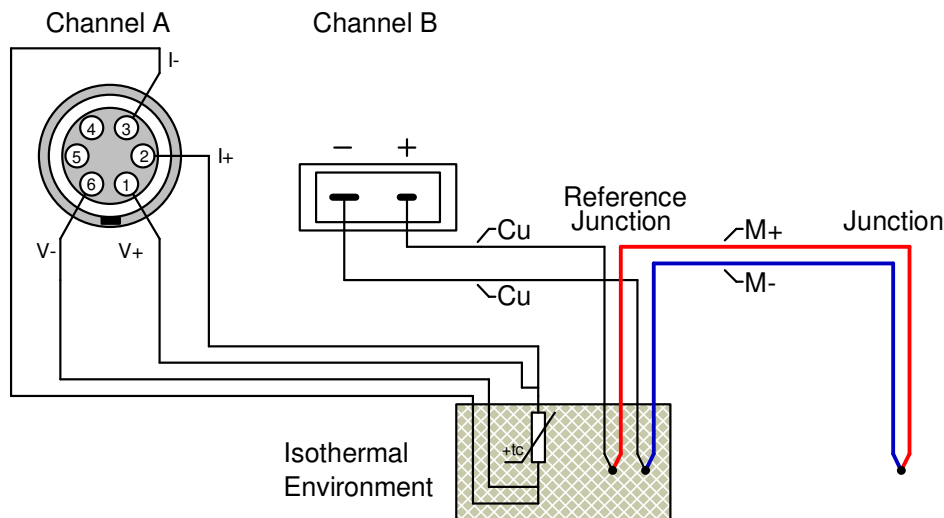

When using a thermocouple with external reference junction compensation, the ‘Reference’ parameter in the **Settings** Window should be set to the channel used to measure the reference junction (see section 3.3.4). Also, you **MUST** use a copper miniature thermocouple connector in order to avoid introducing unwanted additional thermal EMFs. Only channels configured to measure temperature (i.e. having a Conversion defined) appear in the ‘Reference’ parameter list. Thermocouple channels do not appear in the ‘Reference’ parameter list in order to avoid circular dependencies.

For greater accuracy, you can immerse the reference junction in an ice-point at 0°C (see section 3.3.3).

3.3.3 Using an Ice-Point for the Reference Junction

The best measurement uncertainty is generally achieved by immersing the reference junction in an ice-point and measuring the EMF it generates (Isotech can provide ice-point reference systems for this application):

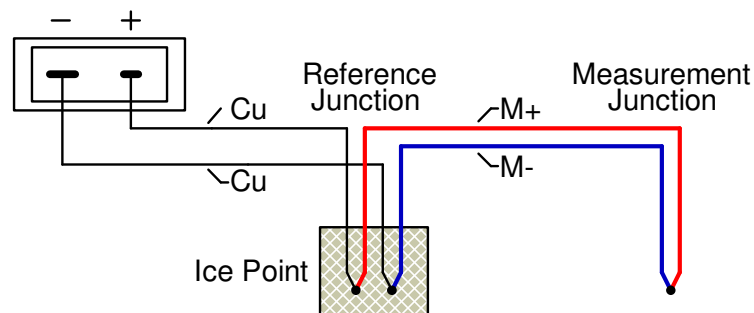

When using a thermocouple with the reference junction in an ice point, the ‘Reference’ parameter in the **Settings** Window should be set to 0°C (see section 3.3.4). Also, you

MUST use a copper miniature thermocouple connector in order to avoid introducing unwanted additional thermal EMFs.

3.3.4 Configuring milliK to Measure a Thermocouple

The milliK can be used with both calibrated and uncalibrated thermocouples. Press the **Settings** (F3) key to access the Settings Window, which opens with the ‘Channel’ parameter selected. Use the **←** **→** keys to select the channel that you want to use. Then use the **↑** **↓** keys to select each parameter in turn and set it to the required value either by using the **←** **→** keys to sequence through the options or pressing the **↵** key to open a new Window with all the options listed. For an uncalibrated thermocouple or one that is not supplied with calibration data, set ‘Thermometer’ to “Default Thermocouple”. If you want to use temperature units, select one of the standard conversions for thermocouples. If your thermocouple is supplied with calibration data (data pairs of polynomial coefficients), you can create a thermometer entry in the database (see section 3.9.5) that uses this data to provide more accurate conversion of the measured EMF to temperature.

A typical configuration for an uncalibrated (type K) thermocouple (using internal reference junction compensation) would be:

Channel	Channel 1
Status	Enabled
Thermometer	Default Thermocouple
Type	Thermocouple
Conversion	Type K
Range	±115mV
Units	°C
Reference Junction	Internal
Samples/Reading	1
Readings in Stats	100

Graph
Numeric
Settings
Instrument

In order to use external reference junction compensation (see section 3.3.2) you must enable and configure one of the other channels to measure temperature using a PRT/SPRT or thermistor. This channel will then appear as one of the options in the ‘Reference Junction’ parameter. A typical configuration for a type T thermocouple (using external reference junction compensation by a PRT connected to channel 2) would be:

Channel	Channel 1
Status	Enabled
Thermometer	Default Thermocouple
Type	Thermocouple
Conversion	Type K
Range	±115mV
Units	°C
Reference Junction	Channel 2
Samples/Reading	1
Readings in Stats	100

Graph Numeric Settings Instrument

The lowest uncertainty can be achieved with a thermocouple by using an ice-point as the reference junction (see section 3.3.3). A typical configuration for a calibrated gold-platinum thermocouple entered into the database as “AuPt thermocpl” and using an ice-point reference would be:

Channel	Channel 1
Status	Enabled
Thermometer	AuPt thermocple
Type	Thermocouple
Conversion	Type Au-Pt
Range	±115mV
Units	Ω
Reference Junction	0°C
Samples/Reading	1
Readings in Stats	100

Graph Numeric Settings Instrument

Once you have configured the milliK to work with your thermocouple, press either the **Graph** (F1) or **Numeric** (F2) keys to view the measurements:

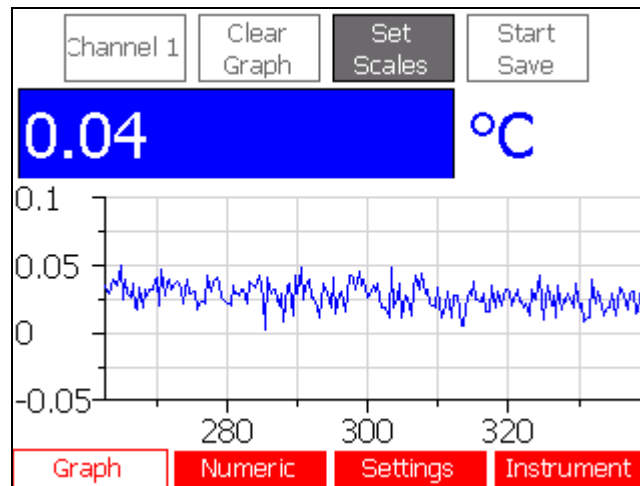

Use the keys to select and activate the on-screen buttons to select the channel, clear the graph, clear the statistics (Numeric Window) set the scales and start/stop logging of data to a file.

3.4 Using a 4-20mA Transmitter with milliK

The milliK can be used with 4-20mA temperature transmitters by using the 4mm sockets on the rear of the milliK (designated Channel 3). The centre 4mm socket is the current sense input to the milliK, the other 4mm sockets are 0V and a +24V supply. Connect the transmitter between the appropriate 4mm sockets depending on whether it is self-powered or loop-powered (suitable for a 24V loop supply):

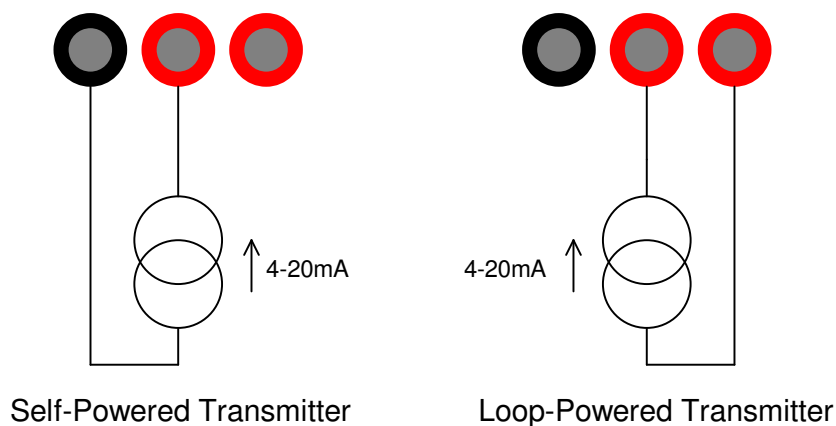

The 4-20mA system and 24V supply are isolated from both the measurement system of Channels 1 and 2 and from the digital interfaces in order to optimise immunity to external (common-mode) noise sources.

3.4.1 Configuring milliK to Measure a 4-20mA Transmitter

The milliK can measure the current output from a 4-20mA transmitter, or it can convert this current to temperature units by defining the conversion in the milliK's thermometer database (see section 3.9.1).

Press the **Settings** (F3) key to access the **Settings** Window, which opens with the 'Channel' parameter selected. Use the **←** **→** keys to select Channel 3 and then use the **↑** **↓** keys to select each parameter in turn and set it to the required value either by using the **←** **→** keys to sequence through the options or pressing the **↓** key to open a new Window with all the options listed. A typical configuration for a 4-20mA transmitter that indicates temperature would be:

Channel	Channel 3
Status	Enabled
Thermometer	0-200C 4-20 TX
Type	4-20mA
Conversion	Linear
Range	30mA
Units	°C
Samples/Reading	1
Readings in Stats	100

Graph Numeric Settings Instrument

Set the 'Thermometer' to "Default 4-20mA" if you just want to measure the output in mA:

Channel	Channel 3
Status	Enabled
Thermometer	Default 4-20mA
Type	4-20mA
Conversion	None
Range	30mA
Units	mA
Samples/Reading	1
Readings in Stats	100

Graph Numeric Settings Instrument

Once you have configured the milliK to work with your 4-20mA transmitter, press either the **Graph** (F1) or **Numeric** (F2) keys to view the measurements:

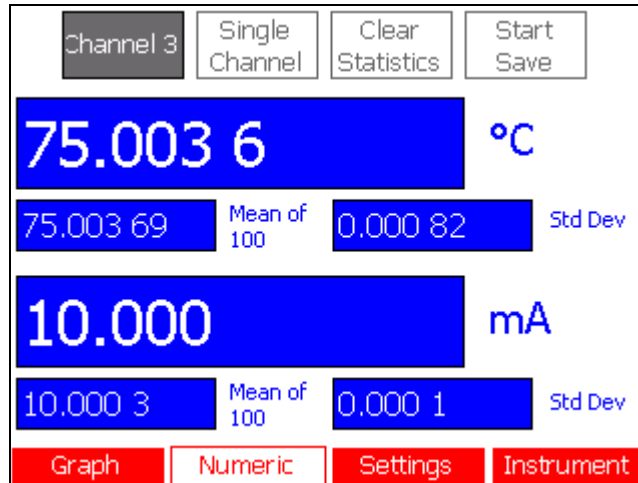

Use the **←** **→** **↑** **↓** **↵** keys to select and activate the on-screen buttons to select the channel, clear the graph/statistics, clear the statistics (Numeric Window) and start/stop logging of data to a file.

3.5 Measuring the Difference Between Two Channels

The milliK can display the difference between any channel and channel 1, provided that the units are the same (otherwise the value would be meaningless). This feature is available in both the **Graph** or **Numeric** Windows where the differential option is listed amongst the other single channels on the **Channel x** button or in the channels list that open when this button is selected. If the units for a channel differ from those of channel 1, the differential option will not be listed.

3.6 Changing Graph Scales

The scales of the graph used to display measurements in the **Graph** Window can be set manually or automatically (adjusts vertical scale to ensure that all available data is visible). Press the **Graph** (F1) key to open the **Graph** Window, use the **←** **→** keys to select the **Set Scales** button and press the **↵** key to open the 'Set Graph Scales' Window:

Set Graph Scales			
X-Axis	Y-Axis		
Minutes	Minimum	Maximum	
60	Auto	Auto	
Change	Change	Change	Automatic
Cancel			OK

Use the **←** **→** keys to select the required parameter and then press the **↓** key open a soft numeric keypad to change the value/setting:

Please enter the X-Axis scale in minutes			
			60
1	2	3	
4	5	6	
7	8	9	
		0	
Cancel		Backspace	OK

When the ‘Automatic/Manual’ button is set to “Automatic”, the buttons to change the y-axis minimum and maximum values are disabled and cannot be selected. Change this to “Manual” in order to access these parameters by selecting the ‘Automatic/Manual’ button and pressing the **↓** key.

3.7 Using Rolling Statistics

The milliK reports the mean and standard deviation of the most recent readings. The number of readings in these rolling statistics can be set independently for each channel in the **Settings** Window. Press the **Settings** (F3) key to open this Window, use the **←** **→** keys to select the required channel and then use the **↑** **↓** keys to select the ‘Readings in Stats’ setting:

Channel	Channel 1
Status	Enabled
Thermometer	AuPt thermocple
Type	Thermocouple
Conversion	Type Au-Pt
Range	±115mV
Units	°C
Reference Junction	0°C
Samples/Reading	1
Readings in Stats	100

Graph Numeric Settings Instrument

Press the key to open a numeric keypad Window and set the required value (between 1 and 1000).

The rolling statistics can be cleared in the **Numeric** Window. Use the keys to select the **Clear Statistics** button and then press the key to clear the statistics:

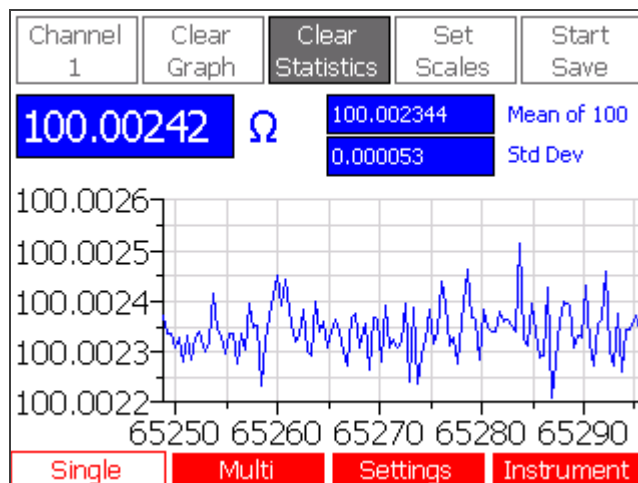

3.8 Logging Results to a File

The milliK can store results to a file on an external USB drive (connected to the USB port on the rear of the instrument) or to internal flash memory. Files stored to internal memory can be transferred to an external USB drive at a later date. The information is stored as comma separated (CSV) ASCII text, which can be imported into applications such as Microsoft Excel™ for further processing. Start or stop the logging of data from within the **Graph** or **Numeric** Windows by using the keys to select the **Start Save** / **Stop Save** button and then pressing the key:

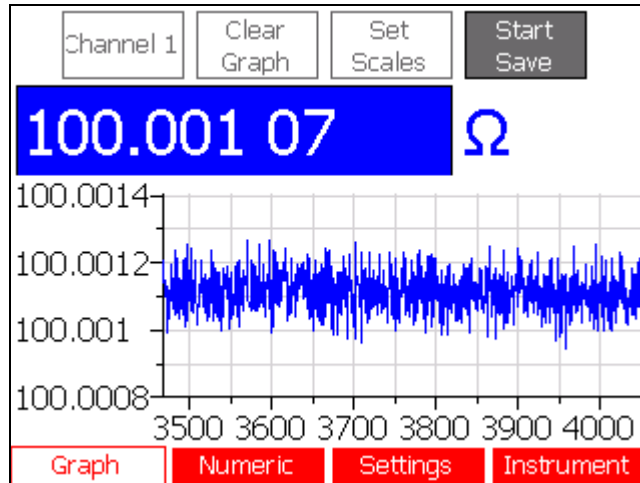

This opens the 'File Location' Window:

Use the **←** **→** keys to select whether to store the file to external or internal memory and then press the **OK** (F4) or **↓** keys to open a soft keyboard and enter a filename (a default filename generated from the date/time is suggested automatically):

3.8.1 Transferring Logged Data to a PC

To transfer data logged data to an external USB drive to a PC, stop the logging (DO NOT remove the USB drive while still logging data to it as the data on the drive may then not be accessible), and transfer the drive to your PC. The file will be located in the root directory of the drive.

To transfer data logged to the milliK's internal memory to a PC, it must first be transferred to a USB drive. Plug the USB drive into the USB port on the rear of the milliK. Press the **Instrument** (F4) key, use the **↑** **↓** keys to select **Backup Logged Data** and then press the **↵** key. All files in the milliK's internal memory will be transferred to the USB drive in a folder located at :\\milliK\\serial_no, where "serial_no" is the serial number of the milliK. If the files already exist on the USB drive, a Window will open allowing you to specify whether or not to overwrite each file (you can specify whether or not to overwrite each individual file or all files):



If you choose to overwrite files, you will be required to enter the password (see section 3.11).

The CSV logged data can be imported into Excel™ by selecting 'Open' in Excel™, selecting "Text Files (*.prn; *.txt; *.csv)" under 'Files of type' and navigating to the required file. A Text Import Wizard will appear; choose "Delimited" as the 'Original data type' in the first Window and ensure that "Comma" is selected as one of the 'Delimiters' in the second Window. The data will then be imported sensibly into the cells of the spreadsheet.

3.8.2 File Format for Logged Data

The first 27 rows of the spreadsheet contain information about the configuration of the milliK during logging. Rows 28 onwards contain the elapsed time (in seconds) and logged data for all channels that are enabled:

	Channel 1	Channel 2	Channel 3
Instrument Name	milliK	milliK	milliK
Serial Number	10-P196	10-P196	10-P196
Firmware Version	1.06	1.06	1.06
Software Version	1.3.5	1.3.5	1.3.5
Enabled	Yes	No	Yes
Range	115Ω	460Ω	30mA
Units	Ω	°C	°C
Current/mA	1mA	1mA	n/a
Reference Junction	n/a	n/a	n/a
Samples per Reading	1	1	1
Readings in Stats	100	100	100
Thermometer	Default 4-Wire PRT	Default 4-Wire PRT	0-200C 4-20 TX
Type	PRT	PRT	4-20mA
Manufacturer			
Model	Default 4-Wire PRT	Default 4-Wire PRT	
Serial Number			
Recalibration Date	31/12/2099	31/12/2099	31/12/2099
Minimum Temperature	-273.15	-273.15	0
Maximum Temperature	2000	2000	200
Temperature Conversion	None	IEC60751 (2008)	Linear
Start Date	15/05/2012		
Start Time	12:51:56		
Elapsed Time/s	Channel 1	Channel 2	Channel 3
	4246.2	100.001157	75.0036
	4247.02	100.001152	75.0036

3.8.3 Clearing Logged Data from Internal Memory

The internal memory has a capacity of almost 4GB, which is sufficient to allow continuous logging at the maximum rate for over 30,000 hours (1,250 days). Clear logged data from the internal memory (to free capacity or discard data) by pressing the **Instrument** (F4) key and using the **↑** **↓** keys to select **Clear Logged Data**:

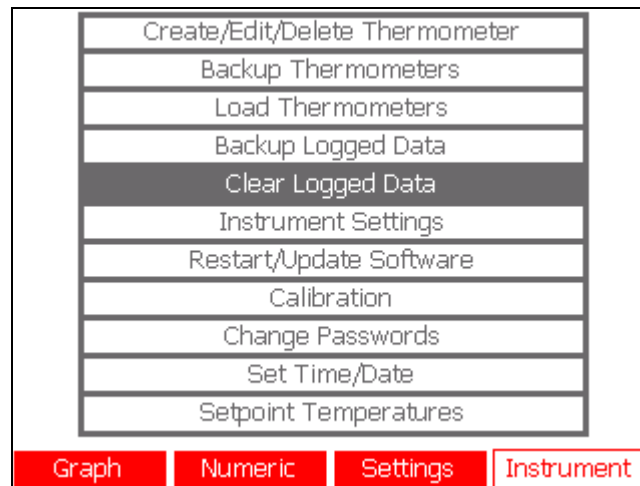

Press the **↓** key to clear the memory. The milliK will then display the number of files you are about to remove and will ask you to provide the password (see section 3.11) in order to proceed.

3.9 Using the Thermometer Database

The milliK includes a database for thermometers you wish to use regularly. You can create, delete or modify thermometers in the database. Information includes details to identify the thermometer (manufacture, model and serial number), track calibration status (re-calibration date), convert readings to temperature (conversion type and coefficients, minimum and maximum operating temperature) and identify whether it uses 3 or 4 wire connection (PRTs only). Thermometers in the database will appear in the list of available ‘Thermometer’ types in the **Settings** Window provided that they are compatible with the selected channel. This means that only thermometers with ‘Type’ set to PRT, Thermocouple or Thermistor will appear for channels 1 and 2 (4-20mA transmitters will not appear).

3.9.1 Creating a New Thermometer Entry

Press the **Instrument** (F4) key, use the **↑** **↓** keys to select **Create/Edit/Delete Thermometer** and press the **↓** key. You will then be asked to enter the password before continuing. A Window will then appear offering the options to create, edit or remove a thermometer:

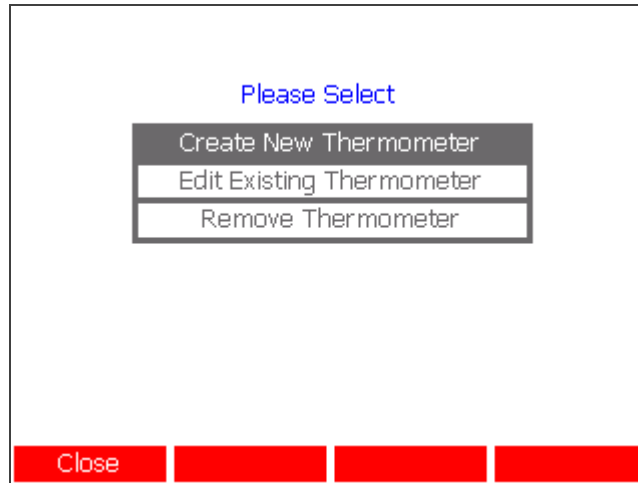

Use the **↑** **↓** keys to select **Create New Thermometer** and press the **↵** key to open the 'Thermometer' Window:

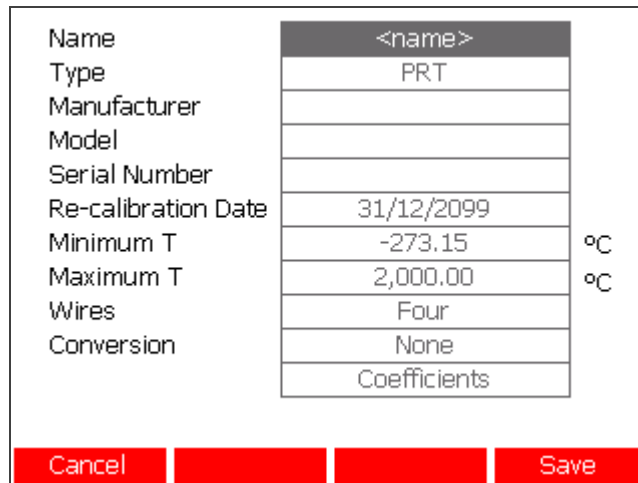

Use the **↑** **↓** keys to select each parameter in turn and press the **↵** key to open a Window and enter a value or select an option. A typical entry for an SPRT would be:

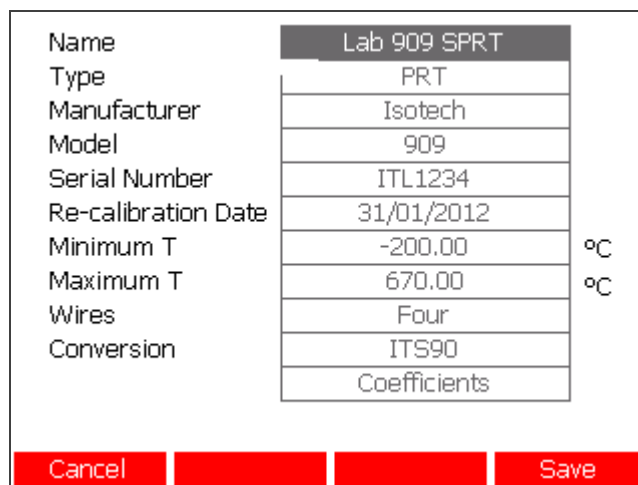

The list of available ‘Conversion’ options and the ‘Coefficients’ used depends on the thermometer ‘Type’ selected (PRT, Thermocouple, Thermistor or 4-20mA):

Thermometer ‘Type’	Available ‘Conversion’
PRT	None IEC60751 (2008) Callendar Van Dusen ITS90
Thermocouple	None Type Au-Pt Type B Type E Type J Type K Type L Type N Type R Type S Type T
Thermistor	None Steinhart-Hart Polynomial
4-20mA	None Linear

Select the ‘Conversion’ you wish to use with the thermometer, then select ‘Coefficients’ and press the  key to enter/view/edit calibration coefficients. A discussion of the various conversion coefficients and their application follows:

3.9.2 Using a PRT with IEC60751 (2008) Conversion

The variation of resistance with temperature for platinum is well known and predictable. The characteristics depend on a number of factors including the purity of the wire. Higher purity platinum wire exhibits greater sensitivity (more resistance change per °C), but is more susceptible to changes caused by contamination that can occur in use. For this reason platinum wire with small amounts of intentional “impurities” (an alloy) is used for many industrial PRTs to make them more stable in use. The most common grade of wire offers a sensitivity for a 100Ω PRT (Pt100) of 0.385 Ω K⁻¹ at 0°C and has a typical generic resistance-temperature characteristic that is defined in standard IEC60751 (2008). You can use the generic IEC60751 (2008) conversion with PRTs that are made with a grade of wire that meets the requirements of the standard. The measurement uncertainty will depend on the class of thermometer and its temperature and can vary from ±0.15°C (Class A Pt100 at 0°C) to ±4.6°C (Class B Pt100 at 850°C).

In the ‘Thermometer’ Window use the \uparrow \downarrow keys to select ‘Conversion’ parameter and then use the \leftarrow \rightarrow keys to select “IEC60751 (2008)”. This standard uses the Callendar Van Dusen equation to convert resistance to temperature. To view the coefficients used in IEC60751 (2008), select ‘Coefficients’ and press the \downarrow key. You cannot change these coefficient, but you will be able to view the coefficients used in the IEC60751 (2008) standard:

IEC60751 (2008) coefficients:	
Ro	100
a	3.908300E-03
b	-5.775000E-07
c	-4.183000E-12
Eqn Form	a,b,c

Cancel

3.9.3 Using a PRT with Callendar Van Dusen Conversion

PRTs and SPRTs can be calibrated individually (resistance-temperature characteristics determined) in order to achieve low uncertainties. There are two algorithms used to represent the thermometer’s characteristic (the Callendar Van Dusen equation and the ITS90 equations). The Callendar Van Dusen equation was developed first and was used as the primary conversion algorithm for all PRTs up until 1990. It is still applicable for PRTs and SPRT, although better uncertainty can be achieved by using the ITS90 equations (particularly important when using higher accuracy SPRTs).

If your thermometer calibration is presented using Callendar Van Dusen coefficients (a,b,c or α,β,δ), use the \uparrow \downarrow keys in the ‘Thermometer’ Window to select ‘Conversion’ and then use the \leftarrow \rightarrow keys to select “Callendar Van Dusen”. Use the \uparrow \downarrow keys to select ‘Coefficients’ and then press the \downarrow key to open the ‘Callendar Van Dusen Coefficients’ Window:

Callendar van Dusen coefficients:

R ₀	100
a	3.908300E-03
b	-5.775000E-07
c	-4.183000E-12
Eqn Form	a,b,c

Cancel OK

Use the \uparrow \downarrow keys to select each parameter in turn and press the \leftarrow key to open a soft numeric keypad and enter the value from the calibration certificate. If no coefficient is supplied (not all coefficients are required), set the value to zero. Select 'Eqn Form' and press the \leftarrow key to toggle between the a,b,c and α,β,δ versions of the equation. The milliK will automatically convert the coefficients as you change the equation form selected.

3.9.4 Using a PRT with ITS90 Conversion

In 1990, the International Temperature Scale was revised and a new set of equations were defined for converting the resistance of a PRT to temperature. These equations (commonly referred to as ITS90) comprise a nominal conversion that represent the average conversion characteristic and deviation functions that provide the adjustment for the characteristics of the individual thermometer. They are intended for use with high purity platinum and provide a better fit than can be achieved with the older Callendar Van Dusen equation. The ITS90 equations are sometimes also used with industrial PRTs, made using the lower sensitivity 0.00385K^{-1} wire and can provide a small improvement in uncertainty compared with the Callendar Van Dusen equation.

If your thermometer calibration is presented using ITS90 coefficients, use the \uparrow \downarrow keys in the 'Thermometer' Window to select 'Conversion' and then use the \leftarrow \rightarrow keys to select "ITS90". Use the \uparrow \downarrow keys to select 'Coefficients' and then press the \leftarrow key to open the 'ITS90 Coefficients' Window:

ITS90 coefficients:

R(0.01) 25.500000000

t < 0.01 °C t > 0.01°C

a	0.000000000E00	a	0.000000000E00
b	0.000000000E00	b	0.000000000E00
		c	0.000000000E00
		d	0.000000000E00
			0.000000000E00

W660.323

Cancel OK

Use the \uparrow \downarrow keys to select each parameter in turn and press the \downarrow key to open a soft numeric keypad and enter the value from the calibration certificate. If no coefficient is supplied (not all coefficients are required), leave the value set to zero. If your thermometer is supplied with a calibration over the range -38.8344°C (mercury triple point) to 29.7646°C (gallium melting point), it should be provided with two coefficients (a and b). To enter these, use the \uparrow \downarrow keys to select the $t < 0.01^{\circ}\text{C}$ button and use the \leftarrow \rightarrow to change this to $-38.8 < t < 29.7^{\circ}\text{C}$. The a and b coefficient can then be entered below the button.

3.9.5 Using a Thermocouple with Calibration Coefficients / Data Pairs

The EMF-temperature characteristics of thermocouples are non-linear and the milliK uses standard algorithms (from IEC584, apart from gold-platinum and type L) to convert the measured EMF to a temperature. Thermocouples can be calibrated individually to achieve better measurement uncertainty. The calibration is presented as a deviation function polynomial or as data pairs. The milliK supports a third-order polynomial correction and data pairs (linear interpolation between the data pairs).

In the ‘Thermometer’ Window use the \uparrow \downarrow keys to select ‘Conversion’ and then use the \leftarrow \rightarrow keys to select the required thermocouple type. Now use the \uparrow \downarrow keys to select ‘Coefficients’ and press the \downarrow key to open the ‘Thermometer Coefficients’ Window:

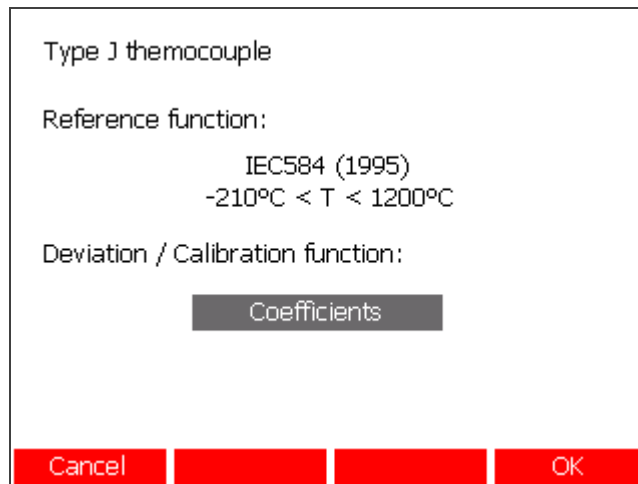

Use the keys to toggle ‘Deviation / Calibration function’ between “Coefficients” and “Data Pairs”. Press the key to open a soft keypad and enter the required data.

If you are entering Data Pairs, use the keys to select either the ‘Temperature / °C’ or ‘EMF / mV’ boxes at the top of the screen and press the key to open a soft keypad and enter the value. To delete a data point, use the keys to select the point and press the **Delete** (F2) key. The “0 , 0.000” point is fixed and cannot be deleted:

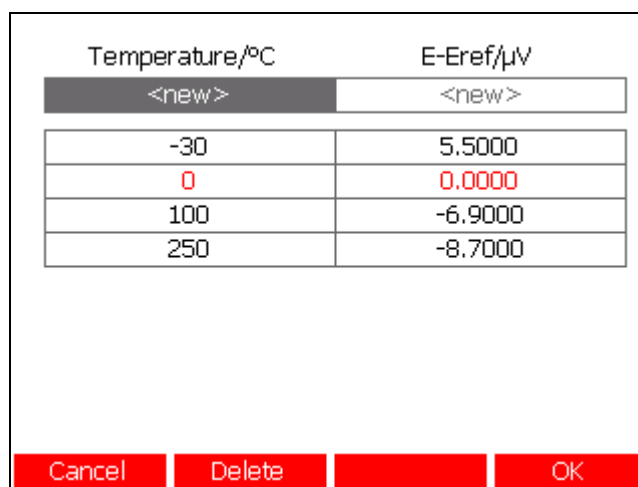

Do not use the thermocouple outside the temperature range defined by the data pairs as errors may be more than those declared in the calibration certificate.

3.9.6 Using a Thermistor with the Steinhart-Hart Polynomial

The resistance-temperature characteristics of a thermistor are highly non-linear (essentially logarithmic). The Steinhart-Hart equation is commonly used to convert the measured resistance to temperature. The three coefficients (A,B,C) used in the equation should be

specified for the thermometer you are using (there is no generic characteristic for thermistors).

Use the \uparrow \downarrow keys in the ‘Thermometer’ Window to select ‘Conversion’ and then use the \leftarrow \rightarrow keys to select “Steinhart-Hart”. Use the \uparrow \downarrow keys to select ‘Coefficients’ and then press the \downarrow key to open the ‘Steinhart-Hart Coefficients’ Window:

Steinhart-Hart coefficients:

A	2.701142E-03
B	-1.310384E-05
C	9.899358E-07

$1/T = A + B \ln(R) + C [\ln(R)]^3$

Cancel

OK

Use the \uparrow \downarrow keys to select each coefficient in turn and press the \downarrow key to open a soft numeric keypad and enter the required value.

3.9.7 Using a Thermistor with Polynomial Temperature Conversion

The milliK uses a third order polynomial with the second order term missing. Recently, some thermistor suppliers have been using a third order polynomial to characterise their thermistors with all four coefficient present (and non zero):

$$\frac{1}{T} = C_0 + C_1 \ln(R) + C_2 [\ln(R)]^2 + C_3 [\ln(R)]^3$$

The milliK supports this full third order conversion. Use the \uparrow \downarrow keys in the ‘Thermometer’ Window to select ‘Conversion’ and then use the \leftarrow \rightarrow keys to select “Polynomial”. Use the \uparrow \downarrow keys to select ‘Coefficients’ and then press the \downarrow key to open the ‘Polynomial Coefficients’ Window:

Polynomial coefficients:

C0	2.701142E-03
C1	-1.310384E-05
C2	0.000000E00
C3	9.899358E-07

$$1/T = C0 + C1 \ln(R) + C2 [\ln(R)]^2 + C3 [\ln(R)]^3$$

Cancel OK

Use the \uparrow \downarrow keys to select each coefficient in turn and press the \downarrow key to open a soft numeric keypad and enter the required value.

3.9.8 Using a 4-20mA Transmitter with Linear Conversion

4-20mA transmitters source a current that is linearly dependent on the measured value. A 4mA current indicates the minimum output value and 20mA indicates the maximum. Current below 4mA is often used to indicate a fault condition in the transmitter.

To use linear interpolation of the current and determine the measured temperature, use the \uparrow \downarrow keys in the ‘Thermometer’ Window to select ‘Conversion’ and then use the \leftarrow \rightarrow keys to select “Linear”. Use the \uparrow \downarrow keys to select ‘Coefficients’ and then press the \downarrow key to open the ‘4-20mA Temperature Linear Conversion’ Window:

4-20mA Temperature Linear Conversion:

Temperature / °C

4mA =	0.00
20mA =	100.00

Cancel OK

Use the \uparrow \downarrow keys to select the temperature at either 4 or 20mA and press the \downarrow key to open a soft numeric keypad and enter the required value.

3.10 Updating the Software

Isotech periodically issue updates to the software to improve performance or add new features. We recommend that you register for update notification, Isotech will then send you an email advising you of updates and new features as they become available. To register, go to <http://isotech.info/milliK>.

The software in your milliK can easily be updated by plugging a USB drive with the updated files (MUST be in root directory) into the USB port on the rear of the milliK and selecting the update software feature. Press the **Instrument** (F4) key and use the **↑****↓** keys to select **Restart/Update Software**, you will then be asked to enter the password in order to continue. The milliK will then display any updates that are found on the USB drive and give you the option to implement the update (before restarting the software).

The software is divided into two parts. The first is designated “software” and provides the user interface. The second is designated “firmware” and manages the hardware that performs the measurements. The update software feature looks for updates to both parts and allows you to install each one individually. The version number of the software and firmware are shown in the opening (Start) Window:

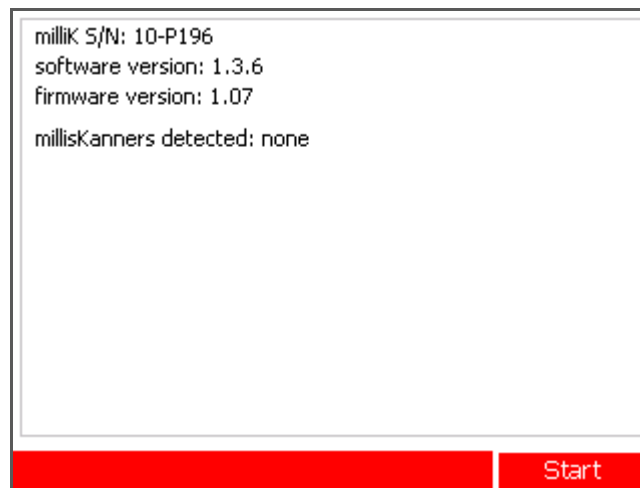

3.11 Using and Changing Passwords

All features that affect measurements (calibration of milliK, calibration data stored in the thermometer database) are password protected. All actions that would lead to loss of data (clearing data logged to internal memory, overwriting files) are also password protected.

The milliK uses two passwords. The main password is used to protect all functions that form part of the normal operator activity (clearing logged data, editing thermometer calibration

data). A separate calibration password is used to protect the milliK's calibration. These are both initially set to "1234", but should be set to something more secure before using the milliK.

To change a password press the **Instrument** (F4) key, use the **↑****↓** keys to select **Change Password**, and then press the **↵** key to open the 'Password Selection' Window:



Use the **↑****↓** keys to select which password you wish to change and then press the **↵** key to open the 'Change Password' Window:

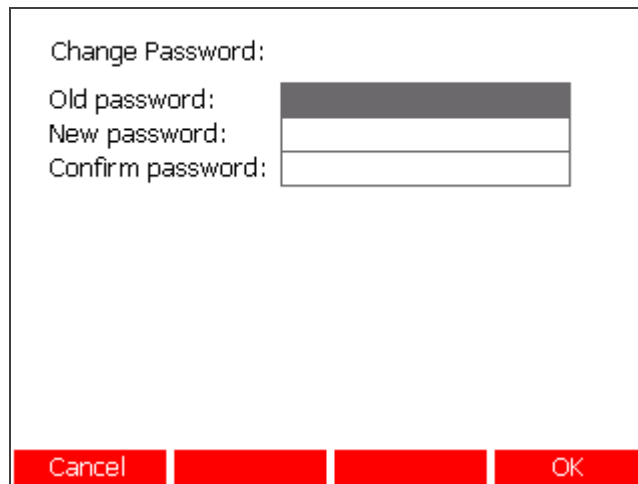

Use the **↑****↓** keys to select each password entry in turn and then press the **↵** key to open a soft keyboard and enter the value. The 'New Password' and 'Confirm Password' entries must be identical (and at least 4 characters long) in order to proceed.

3.11.1 Recovering a Lost Password

Passwords are encrypted before being stored in the milliK, so it is not possible to recover a lost password. If a password is lost, you can get a temporary password from Isotech that will allow you to change the password to a new one. This temporary password can only be generated from a password recovery key generate by your milliK (Isotech cannot supply a universal recovery password).

If you lose your password, go to the Change Password Window (see section 3.11) and press the F2 key (not labelled on screen), the milliK will then generate the recovery key:

Change Password:

Temp Password

New password:

Confirm password:

Please call Isothermal Technology and quote the password recovery key below. You will then be given a temporary password which you should enter above.

Key: ad414afe

Cancel OK



Email this recovery key to Isotech and we will send you a temporary password to enable you to change the password to a new value. Enter this temporary password as the 'Old Password' in the 'Change Password' Window. Once you have changed the password, the temporary password will no longer work; if you forget your password again repeat the above procedure.

3.12 Controlling Temperature Sources with milliK

The milliK can control an Isotech temperature source, changing the set-point at user defined intervals whilst monitoring thermometers in order to provide fully automated calibration.

The milliK must be connected to the temperature source with an RS232-to-RS422 converter cable, these are the yellow cables supplied with each Isotech temperature source. You can connect to either RS232 port on the milliK, as it automatically discovers any temperature source on restart and configures that port to use the Modbus protocol required to control the

temperature source. Restart the milliK (cycle the power or use the “Restart/Update Software” button in the ‘Instrument’ Window) with the lead connected and the temperature source powered to establish a connection. The milliK will then add buttons at the bottom of the ‘Settings’ Window to allow you to select a temperature profile:

Channel	Channel 1
Status	Enabled
Thermometer	Default Thermocouple
Type	Thermocouple
Conversion	None
Range	±115mV
Units	mV
Reference Junction	0°C
Samples/Reading	1
Readings in Stats	100
Setpoint Temp	None
Setpoint Status	Stopped

Graph Numeric Settings Instrument

The ‘Setpoint Temp’ button allows you to select a temperature profile (or disable this feature by selecting “None”). Temperature profiles can be created in the ‘Instrument’ Window (see section 3.12.1). Use the keys to select the ‘Setpoint Temp’ button and press the key to open the ‘Setpoint List’ Window:

Select Setpoint Profile			
None			
PRT Cal 0-200C			
Cancel	Page Up	Page Down	OK

Use the keys to select the required profile or select “None” to disable sequencing of the temperature set point, then press the **OK** (F4) key. If the profile has been configured to start “Immediately” then when you press the **OK** (F4) key the first set point will be sent to the temperature source. Otherwise, (if the profile has been configured to start “On Save”) the first

set point will be sent when you start logging data. When a profile has started, the current set point and duration will be shown in the ‘Setpoint Status’ box:

Channel	Channel 1
Status	Enabled
Thermometer	Default Thermocouple
Type	Thermocouple
Conversion	None
Range	±115mV
Units	mV
Reference Junction	0°C
Samples/Reading	1
Readings in Stats	100
Setpoint Temp	PRT Cal 0-200C
Setpoint Status	Step 1 of 2 for 30 min at 50°C

Graph Numeric Settings Instrument

3.12.1 Creating a Temperature Profile

The milliK allows you to define temperature profiles and store these in a database. To create a new profile press the **Instrument** (F4) key, use the **↑** **↓** keys to select **Setpoint Temperatures** and then press the **↵** key to open the ‘Temperature Profile Menu’ Window (you will need to enter the password to access this Window):



Use the **↑** **↓** keys to select whether you wish to create, edit or delete a profile and then press the **↵** key to open the ‘Temperature Profile’ Window:

Name: <name>

Time / Minutes	Temperature / °C
Immediately	

Cancel Clear Line Clear All OK

Use the **↑** **↓** **←** **→** keys to move between items and then press the **⏏** key to open a keyboard Window to enter values. Press the **⏏** key whilst “Immediate” is selected to toggle between “Immediate” (profile starts as soon as the **OK** (F4) key is pressed when the profile is selected) and “On Save” (profile starts when you start logging data with the ‘Start Save’ button, see section 3.8). The “Time” is the time interval between the last and current set point change.

Name: PRT Cal 0-200C

Time / Minutes	Temperature / °C
Immediately	0
+30	50
+30	100
+45	150
+45	200
+45	0

Cancel Clear Line Clear All OK

To create a fixed set point, make only a single temperature entry.

4 Connecting Thermometers to milliK

Channels 1 and 2 on the front of the milliK are intended for connection to either resistance thermometers (PRTs/SPRTs or thermistors) or thermocouples. Each channel is equipped with a Lemo 6-pin circular connector (for resistance thermometers) and a miniature thermocouple connector. Isotech can supply thermometers fitted with connectors suitable for use with your milliK. In addition each milliK is supplied with 2 Lemo connectors for you to fit to your own thermometers. The part number of these Lemo connectors is:

FGG.1B.306.CLAD62Z

Additional connectors are readily available internationally from Farnell Electronics and can be ordered via their website www.farnell.com (Farnell stock code 3817325).

The pin-out of the Lemo connectors (looking into the milliK) is:

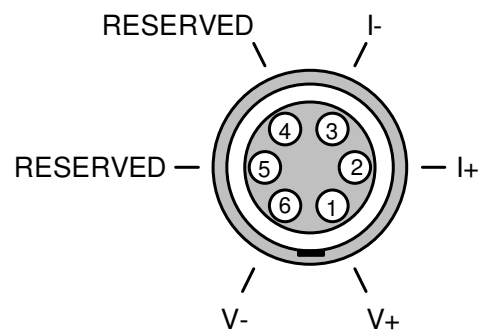

The polarity of the miniature thermocouple connectors is generally marked on the plugs fitted to the thermocouple (the wider pin is the negative connection).

Channel 3 on the rear of the milliK is intended for connection to 4-20mA transmitters and uses 4mm sockets.

4.1 Connecting PRTs/SPRTs to milliK

Most PRTs/SPRTs are supplied with a 4-wire connection so as to eliminate the effect of cable resistance on the measurement (see section 3.1.3). Connect the wires as shown (if the cable is screened, ensure that it is connected to the body of the Lemo connector):

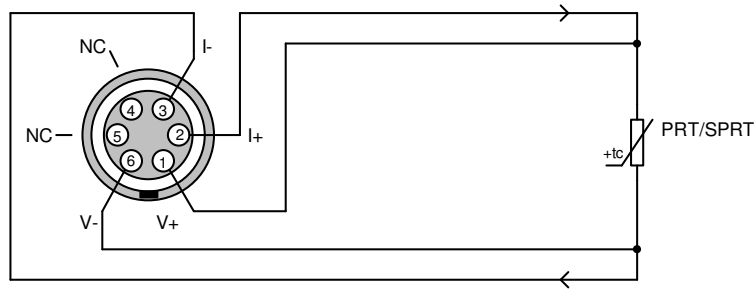

If the PRT is supplied with only a 2-wire connection, convert from 4-wire to 2-wire connection as close to the PRT as possible:

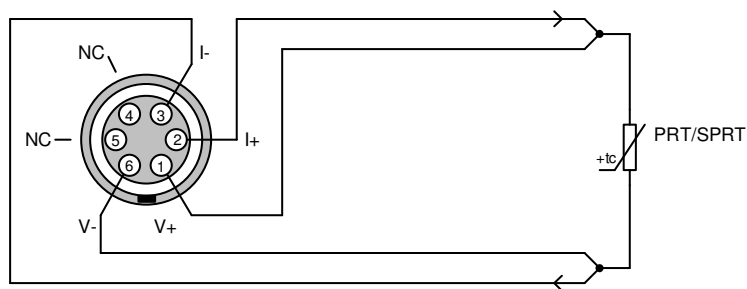

If the PRT is supplied with a 3-wire connection, the current and common wires should be of the same resistance (of same length and gauge) and connected directly to I+ and I- (pins 2 and 3) and a link that carries no current should be made from pin 1 to pin 2 (see section 3.1.3):

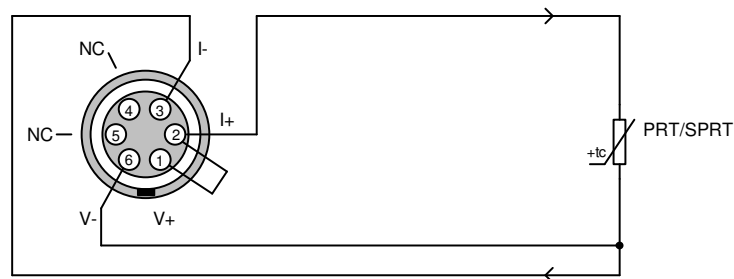

4.2 Connecting Thermistors to milliK

High accuracy thermistor based thermometers are typically supplied with screened 4-wire cables. The relatively high resistance of thermistors makes them more susceptible to external noise, so it is important to connect the cable screen (if provided) to the body of the Lemo connector.

Use the same 4-wire connection as is employed with PRTs so as to eliminate the effect of cable resistance on the measurement:

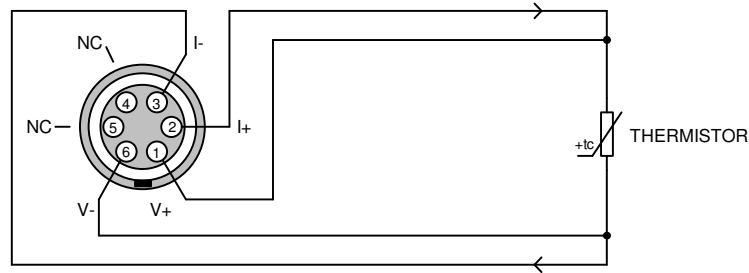

The relatively high resistance of thermistors means that they are used with much lower sense currents ($2\mu\text{A}$ on milliK) than PRTs/SPRT and the effect of the cable resistance is much lower. Thermistors are therefore sometimes supplied with only 2-wire connections, in which case they can be connected to the milliK as follows:

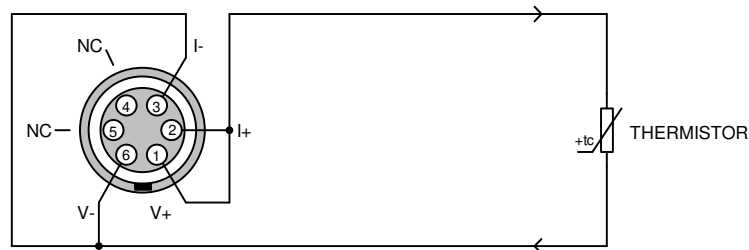

4.3 Connecting Thermocouples to milliK

In order to connect thermocouples to your milliK, fit a suitable miniature thermocouple plug (conforming to ASTM 1684-05) and connect it to one of the thermocouple sockets on the front panel. The plug should be a copper type (contacts made of copper) if using a thermocouple with an accessible reference junction that is measured by a separate thermometer (external compensation) or in an ice point (0°C reference junction temperature). If you wish to use internal reference junction compensation, fit a thermocouple plug that matches the thermocouple type (contacts made of the same metal/alloy used in making the thermocouple), the reference junction is then formed inside the connector.

4.4 Connecting 4-20mA Transmitters to milliK

In order to connect a 4-20mA transmitter to your milliK, fit 4mm plugs to your transmitter. The milliK supports both self-powered and loop-powered transmitters by providing a 24V DC supply. Connect the transmitter to the 4mm sockets on the rear panel of the milliK using the required configuration:

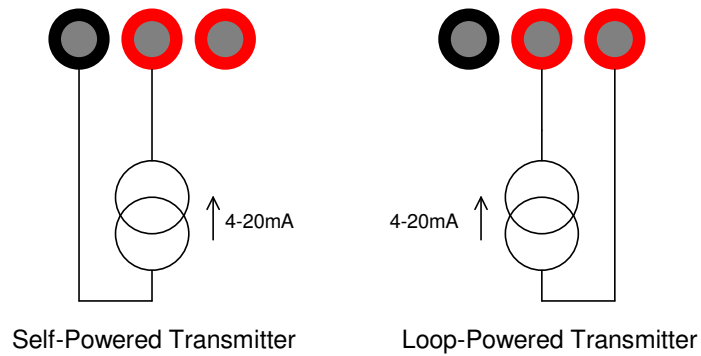

5 Calibration

The calibration of your milliK can be checked by applying standards to the inputs and noting the indicated readings.

The milliK includes calibration software that allows you to adjust its calibration. The process involves attaching suitable standards to the inputs and entering the values of these standards, the calibration software then monitors the measured values and applies any required corrections. The calibration data is stored in an internal comma-separated variable (CSV) file that includes the whole calibration history (time/date stamped) back to its original factory calibration. The calibration file can be exported to a USB drive so that it can be read (for example, by importing it into Microsoft Excel™). The calibration software requires you to enter additional information (such as model/serial numbers of the standards used) in order to document the calibration history of your milliK.

Typically a calibration process will involve measuring the pre-adjustment calibration of the milliK, then making any necessary calibration adjustments and finally checking the calibration after adjustment. The calibration should be checked or adjusted in a temperature controlled environment between 19 and 25°C. The milliK should be powered up (press the Start key (F4) in the opening screen to ensure that the measurement system is initialised and running) and left to stabilise in the calibration environment for at least 3 hours before checking or adjusting its calibration.

All of the adjustment is implemented in software (there are no adjustment potentiometers inside the milliK so as to maximise reliability and provide adjustment that does not drift with time or temperature). The milliK provides the following software adjustments:

- ‡ Gain adjustment for the 115Ω range
- ‡ Gain adjustment for the 460Ω range
- ‡ Gain adjustment for the 500k Ω range
- ‡ Voltage offset adjustment for Channel 1
- ‡ Voltage offset adjustment for Channel 2
- ‡ Gain adjustment for the 115mV range
- ‡ Gain adjustment for the 30mA (4-20mA input) range
- ‡ Offset adjustment for the internal reference junction sensor

The gain adjustments are common to all channels. There are no zero adjustments for the resistance ranges since the zero readings are more than adequate (by design) without the need for any adjustment.

5.1 Standards Required for Calibration

The following standards are recommended for checking or adjusting the calibration:

- ‡ A 4-terminal short circuit (see section 5.1.1 for details of how to make one)
- ‡ A calibrated 100 Ω resistor of suitable quality.
- ‡ A calibrated 400 Ω resistor of suitable quality
- ‡ A calibrated 500k Ω resistor of suitable quality
- ‡ A 0mV short-circuit connected to a miniature thermocouple plug (see section 5.1.2 for details of how to make one)
- ‡ A 10mA precision current reference, such as the Metron Designs I-REF2. This is used to calibrate the 4-20mA input but it can also be used in calibrating the 115mV input by connecting it to a calibrated 10 Ω resistor of suitable quality to generate a nominal 100mV calibration signal. A 100mV signal source can be used to check and adjust the voltage measurement system, but since we are trying to calibrate at the <1 μ V level, suitable calibration sources are expensive. Since you already need a 10mA source to calibrate the 4-20mA input, using a calibrated 10 Ω resistor to generate the signal offers a reliable and inexpensive solution.
- ‡ A calibrated 10 Ω resistor for use with the 10mA source to generate a 100mV signal
- ‡ A thermocouple of adequate quality. A type T thermocouple is suitable since it has a high sensitivity near ambient temperatures and is readily available.

All the calibrated resistors used should be either a Wilkins resistance standard or a high stability foil resistor such as a hermetically sealed Vishay Z-foil resistor (or the H series for the 10 Ω resistor). The resistors should be maintained in a stable temperature environment (such as a silicone oil bath) whose temperature is near to the resistor's calibration temperature and that is monitored so that compensation can be applied for its temperature coefficient of resistance (TCR).

5.1.1 Making a 4-Terminal Short-Circuit

A 4-terminal short circuit is a connection that measures as 0 Ω when measured as a 4-terminal resistance. It can be fabricated using standard copper wire by shorting together the current connections and the voltage connections separately and then linking together these two short-circuits with a single connection:

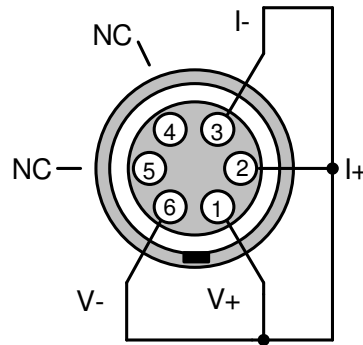

It is important that none of the current flowing between I+ and I- flows along the short circuit between V+ and V-. There should only be a single link between the voltage and current circuits, as shown.

5.1.2 Making a 0mV Source in a Thermocouple Connector

A 0mV source is essentially a piece of copper wire that can be connected across the thermocouples inputs of the milliK. However, you need to take care in making this short circuit in order to avoid creating thermal EMFs that are significant for an instrument as sensitive as the milliK.

The best method for making a 0mV source is to take a copper miniature thermocouple plug and short together the two pins of the connectors with a short length of copper wire. The copper wire should remain inside the connector housing, be as short as possible and go directly between the two terminals of the connector. Ideally, the wire used should be high purity copper, but single stranded copper wire (tinned, plated or unfinished) will provide adequately low thermal EMFs in this arrangement. Using a longer (even just 15mm in length) piece of normal wire that goes outside the connector housing can produce measurable thermal EMFs.

5.2 Checking the Calibration

The calibration of the milliK can easily be checked by attaching reference standards (calibrated resistors, voltage source or current source) to the milliK and measuring their values. Typically you would check the following:

- ‡ 0Ω reading on the 115Ω range
- ‡ 100Ω reading on the 115Ω range
- ‡ 400 Ω reading on the 460Ω
- ‡ 500k Ω reading on the 500Ω
- ‡ 0mV on the 115mV range

- ⌋ 100mV on the 115mV range
- ⌋ 10mA on the 30mA range
- ⌋ A known temperature measured using a thermocouple and internal reference junction compensation

The measurements should be made independently on both channels.

5.2.1 PRT/SPRT Resistance Range

Checking the resistance ranges used for PRT/SPRTs (115Ω and 460Ω) involves checking the values indicated at zero (0Ω) and approximately full-scale (100Ω and 400Ω) on both channels.

5.2.1.1 PRT/SPRT Resistance Range – Zero Check

The current reversal employed by the milliK eliminates the effect of thermal EMFs and provides an inherently stable zero for resistance measurement. There is therefore no zero adjustment for resistance and the zero check is only used to confirm correct operation of the milliK.

Apply a 4-terminal short-circuit (see section 5.1.1) to channel 1 and set the milliK to read its resistance on the 115Ω range at 1mA by changing the parameters in the **Settings** Window:

Channel	Channel 1
Status	Enabled
Thermometer	Default 4-Wire PRT
Type	PRT
Conversion	None
Range	115Ω
Units	Ω
Current	1mA
Samples/Reading	1
Readings in Stats	100

Graph
Numeric
Settings
Instrument

Next, press the **Numeric** (F2) key, clear the statistics and wait for 100 measurements to be made (when the display shows “Mean of 100”). The specification states that the accuracy across the range should be within ±7ppm of range, which equates to 0.00080Ω, however this zero reading should be <±0.00010Ω. After checking the zero-ohm reading on channel 1, repeat the measurement on channel 2. There is no adjustment possible for zero resistance

readings, so if the zero readings fall outside the limits you should return your milliK to Isotech for investigation.

5.2.1.2 SPRT Resistance Range (115Ω) – Span Check

Connect a calibrated (nominally) 100Ω resistor to channel 1 and set the milliK to read its resistance on the 115Ω range at 1mA by changing the parameters in the ‘Settings’ Window (see section 5.2.1.1 for details of settings). Press the **Numeric** (F2) key, clear the statistics and wait for 100 measurements to be made (when the display shows “Mean of 100”). The mean value indicated by the milliK should be compared with the calibrated value of the resistor (apply a correction to the value of the resistor if its temperature coefficient of resistance is significant). Repeat the procedure on Channel 2.

5.2.1.3 PRT Resistance Range (460Ω) – Span Check

Connect a calibrated (nominally) 400Ω resistor to channel 1 and set the milliK to read its resistance on the 460Ω range at 1mA by changing the parameters in the ‘Settings’ Window:

Channel	Channel 1
Status	Enabled
Thermometer	Default 4-Wire PRT
Type	PRT
Conversion	None
Range	460Ω
Units	Ω
Current	1mA
Samples/Reading	1
Readings in Stats	100

Graph
Numeric
Settings
Instrument

Press the **Numeric** (F2) key, clear the statistics and wait for 100 measurements to be made (when the display shows “Mean of 100”). The mean value indicated by the milliK should be compared with the calibrated value of the resistor (apply a correction to the value of the resistor if its temperature coefficient of resistance is significant). Repeat the procedure on Channel 2.

5.2.2 Thermistor Resistance Range (500kΩ) – Span Check

Connect a calibrated (nominally) 500kΩ resistor to channel 1 and set the milliK to read its resistance on the 500kΩ range by changing the parameters in the ‘Settings’ Window:

Channel	Channel 1
Status	Enabled
Thermometer	Default Thermistor
Type	Thermistor
Conversion	None
Range	500k Ω
Units	Ω
Current	2 μ A
Samples/Reading	1
Readings in Stats	100

Graph Numeric Settings Instrument

The high resistance used makes the input prone to picking up electrical interference, so the connection to the resistor should ideally use screened cable (see section 4.2). Press the **Numeric** (F2) key, clear the statistics and wait for 100 measurements to be made (when the display shows “Mean of 100”). The mean value indicated by the milliK should be compared with the calibrated value of the resistor (apply a correction to the value of the resistor if its temperature coefficient of resistance is significant). Repeat the procedure on Channel 2.

5.2.3 Thermocouple Voltage Range – Zero Check

Connect a 0mV source (see section 5.1.2 for details of how to make a 0mV short-circuit) to channel 1 and set the milliK to read voltage by changing the parameters in the ‘Settings’ Window:

Channel	Channel 1
Status	Enabled
Thermometer	Default Thermocouple
Type	Thermocouple
Conversion	Type J
Range	\pm 115mV
Units	mV
Reference Junction	0 $^{\circ}$ C
Samples/Reading	1
Readings in Stats	100

Graph Numeric Settings Instrument

Press the **Numeric** (F2) key, clear the statistics and wait for 100 measurements to be made (when the display shows “Mean of 100”). The mean value indicated by the milliK is the zero reading for voltage measurement on channel 1. Repeat the procedure on Channel 2.

5.2.4 Thermocouple Voltage Range – Span Check

Connect a calibrated (nominally) 100mV voltage source to channel 1 using a copper miniature thermocouple connector. It is difficult to find signal generators that have an adequate specification to check the performance of the milliK. However, you can create your own system by connecting a calibrated 10mA current source to a 10Ω 4-terminal calibrated resistor:

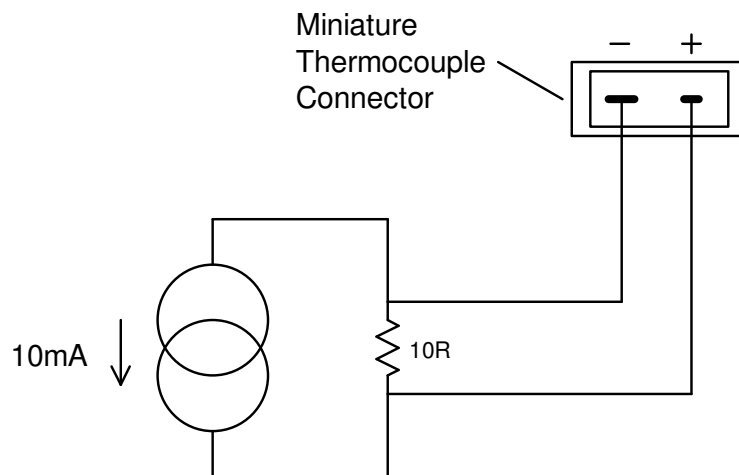

The connections from the 10Ω resistor to the thermocouple connector should be entirely in copper and should not involve intermediate connectors (to avoid thermal EMFs). Set the milliK to read this voltage by changing the parameters in the ‘Settings’ Window (see section 5.2.3 for details of settings).

Press the **Numeric** (F2) key, clear the statistics and wait for 100 measurements to be made (when the display shows “Mean of 100”). The mean value indicated by the milliK should be compared with the calculated value of the applied voltage (apply a correction to the value of the resistor if its temperature coefficient of resistance is significant, as is often the case for low ohmic values such as 10Ω). Repeat the procedure on Channel 2.

5.2.5 4-20mA Transmitter Range – Zero and Span Check

Set the milliK to read the current on channel 3 by changing the parameters in the ‘Settings’ Window:

Channel	Channel 3
Status	Enabled
Thermometer	Default 4-20mA
Type	4-20mA
Conversion	None
Range	30mA
Units	mA
Samples/Reading	1
Readings in Stats	100

Graph Numeric Settings Instrument

Press the **Numeric** (F1) key, select channel 3, clear the statistics and wait for 100 measurements to be made (when the display shows “Mean of 100”). The mean value indicated by the milliK is the zero reading for current measurements.

Connect a calibrated (nominally) 10mA current source to channel 3 (rear panel):

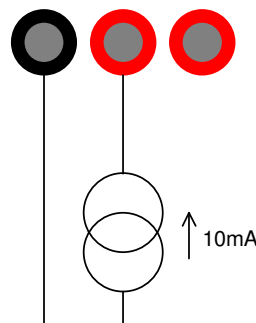

Calibrated Current Source

Clear the statistics and wait for 100 measurements to be made. The measurement system is very low noise so it is likely that you will see the readings dithering between 2 values separated by the milliK’s current resolution ($<0.001\text{mA}$). The mean value indicated by the milliK should be compared with the current source’s calibrated value.

5.2.6 Reference Junction Compensation Accuracy

Check the accuracy of the internal reference junction compensation (RJC) system by connecting a thermocouple to the milliK and measuring a known temperature using internal RJC mode. Any discrepancy between the measured and known temperature indicates an error in the RJC system (or the thermocouple used). You can use any thermocouple type for the measurement, but we recommend type J thermocouples as these have high sensitivity near

room temperature and are readily available (the thermocouple needs to be fitted with a type J miniature thermocouple plug).

Connect the thermocouple to channel 1 and set the milliK to read °C with internal RJC by changing the parameters in the ‘Settings’ Window:

Channel	Channel 1
Status	Enabled
Thermometer	Default Thermocouple
Type	Thermocouple
Conversion	Type J
Range	±115mV
Units	°C
Reference Junction	Internal
Samples/Reading	1
Readings in Stats	100

Graph Numeric Settings Instrument

Press the **Numeric** (F2) key, clear the statistics and wait for 100 measurements to be made (when the display shows “Mean of 100”). The mean value indicated by the milliK should be compared with the known temperature. Any discrepancy may be the result of errors in the RJC system or the thermocouple used. You might consider using an ice bath for the “known” temperature, and this is a reasonable choice. However, the error on a type J thermocouple, even at 20°C might be 5µV (or even higher), which corresponds to a temperature error of approximately 0.2°C. An alternative approach would be to use room temperature as the “known” temperature and to measure this with a calibrated PRT connected to the milliK. This approach has the advantage that the difference between room temperature and the reference junction in the milliK is likely to be very small (< 3°C) so any error resulting from imperfections in the thermocouple will also be small. You need to ensure that the thermocouple is at the same temperature as the PRT. You can create an adequate isothermal environment using a stainless steel vacuum flask filled with silicone oil and agitated with a small air pump of the type designed to aerate fish tanks. Clip the thermocouple to the PRT such that the junction is near to the sensing element in the PRT (perhaps 1-2cm from the end) with nylon cable ties and immerse the assembly in the oil.

Repeat the procedure on Channel 2.

5.3 Adjusting the Calibration

It is common (good) practice to check the calibration of an instrument before making any adjustment (see section 5.2 for information on checking the calibration of your milliK). After adjusting the calibration of your milliK, its calibration should again be checked and the values used to generate a report on its post-adjustment calibration.







The frequency of calibration is for the user to determine, but Isotech recommend that you calibrate your milliK on an annual basis (the specification for the milliK is given in terms of an initial calibration and additional uncertainty over a 1 year period). The values used to adjust the calibration, together with information on the standards used and the calibration conditions are all stored in a comma-separated (CSV) file that can be exported for viewing on a PC, giving the whole calibration history of the instrument from its initial factory calibration.

The milliK includes calibration software that allows you to adjust all the calibration parameters. Adjustment simply requires you to attach reference standards (calibrated resistors, voltage source or current source) to the milliK and invoke the calibration features.

Typically a calibration adjustment involves the following:

- ⌵ Adjust 100Ω reading on the 115Ω range
- ⌵ Adjust 400 Ω reading on the 460Ω
- ⌵ Adjust 500k Ω reading on the 500Ω
- ⌵ Adjust 0mV reading on channel 1
- ⌵ Adjust 0mV reading on channel 2
- ⌵ Adjusting 100mV reading on the 115mV range
- ⌵ Adjusting 10mA reading on the 30mA range
- ⌵ Adjusting the offset for the reference junction sensor

5.3.1 Starting the Calibration Adjustment Feature

Press the **Instrument** (F4) key, use the   keys to select 'Calibration' and then press the  key to start the calibration. You will be asked to enter the calibration password (see section 3.11) after which the 'Calibration' Window will appear, use the   keys to select each parameter in turn and then press the  key to enter information that allows the calibration to be identified. This information is stored in the calibration file for information purposes only and you will not be allowed to proceed without entering something (at least one character) for every parameter:

Calibration	
Date:	08/04/2011
Name:	John Smith
Company:	Isothermal Technology
Location:	Secondary Lab
Room T/°C:	19-21C

Press the **OK** (F4) key to proceed to the 'Calibration Menu' Window:

Please Select

115Ω Range
460Ω Range
500kΩ Range
0mV Range
115mV Range
4-20mA Range
RJ Sensor

5.3.2 Adjusting SPRT (115Ω) Resistance Range

Connect a calibrated (nominally) 100Ω resistor to channel 1. In the 'Calibration Menu' Window, use the **↑↓** keys to select '115Ω Range' and then press the **↵** key to proceed to the '115Ω Calibration Adjustment' Window. Use the **↑↓** keys to select the two required parameters in turn and press the **↵** key to enter their values:

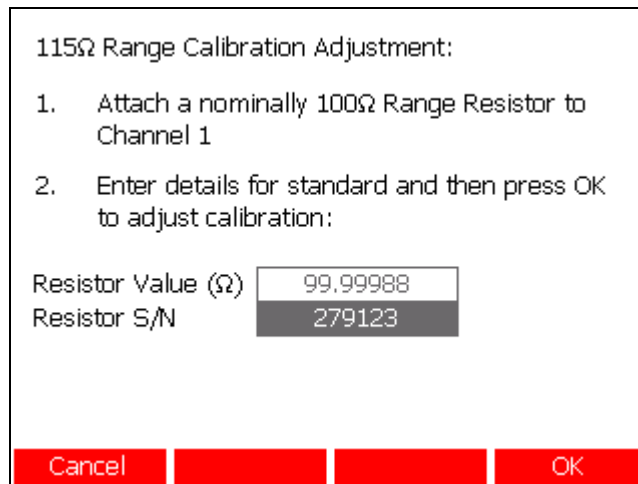

Press the **OK** (F4) key to start the calibration adjustment. The milliK will then take a number of readings of the attached resistance standard, calculate and then apply an appropriate adjustment. A progress bar appears showing the status of the calibration adjustment:

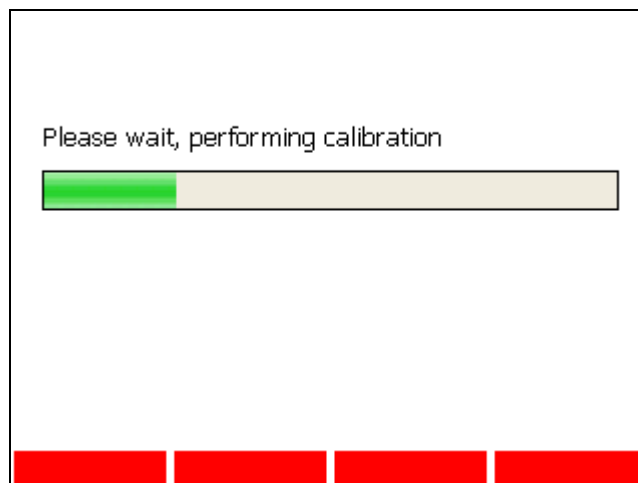

Once started, the calibration adjustment process cannot be aborted.

5.3.3 Adjusting PRT (460Ω) Resistance Range





Connect a calibrated (nominally) 400Ω resistor to channel 1. In the 'Calibration Menu' Window, use the **↑****↓** keys to select '460Ω Range' and then press the **↵** key to proceed to the '460Ω Calibration Adjustment' Window and use the same procedure described for calibrating the 115Ω range (see section 5.3.2) to adjust this range.

5.3.4 Adjusting Thermistor (500kΩ) Resistance Range

Connect a calibrated (nominally) 500kΩ resistor to channel 1. In the 'Calibration Menu' Window, use the **↑****↓** keys to select '500kΩ Range' and then press the **↵** key to proceed to

the ‘500kΩ Calibration Adjustment’ Window and use the same procedure described for calibrating the 115Ω range (see section 5.3.2) to adjust this range.





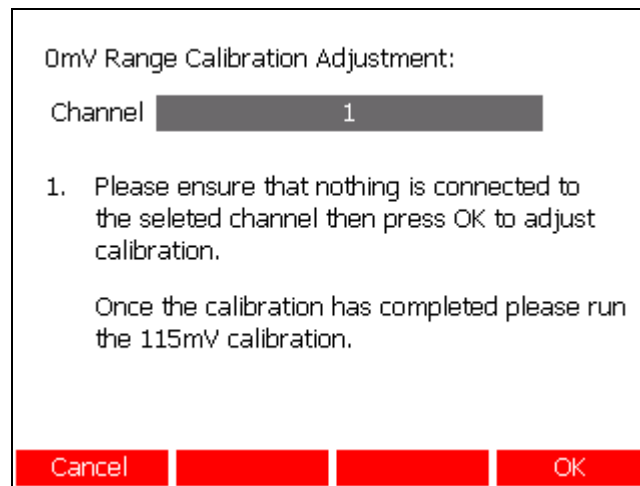



5.3.5 Adjusting Zero Voltage Offsets

Connect a 0mV short circuit (see section 5.1.2) to the miniature thermocouple connector for channel 1. In the ‘Calibration Menu’ Window, use the   keys to select ‘0mV Range’ and then press the  key to proceed to the ‘0mV Calibration Adjustment’ Window. Use the   keys to select channel 1:



Press the  (F4) key to start the calibration adjustment. Once started, the calibration adjustment process cannot be aborted. Repeat the procedure on Channel 2.

5.3.6 Adjusting Voltage Gain

Connect a calibrated (nominally) 100mV signal to channel 1 (see section 5.2.4 for information on generating a suitable signal). In the ‘Calibration Menu’ Window, use the   keys to select ‘115mV Range’ and then press the  key to proceed to the ‘115mV Calibration Adjustment’ Window. Use the   keys to select channel 1 and then use the   keys to select each parameter in turn and press the  key to enter their values. The ‘Standard S/N’ and ‘Additional Info.’ fields can be used to record information on the standard used. If you generate the 100mV using a 10Ω resistor with serial number 2791555 and a 10mA current source with serial number 2-M52-S52, suitable entries would be:

115mV Range Calibration Adjustment:	
Channel	<input type="text" value="1"/>
1. Apply 100mV to the selected channel	
2. Enter details for standards used and then press OK to adjust calibration:	
Voltage Applied (mV)	<input type="text" value="100.001213"/>
Standard S/N	<input type="text" value="2791555"/>
Additional Info.	<input type="text" value="2-M52-S52"/>
<input type="button" value="Cancel"/> <input type="button" value="OK"/>	

Press the **OK** (F4) key to start the calibration adjustment. Once started, the calibration adjustment process cannot be aborted.

5.3.7 Adjusting 4-20mA Transmitter Range

Connect a calibrated (nominally) 10mA current source to the 4mm sockets designated channel 3 on the rear of the milliK:

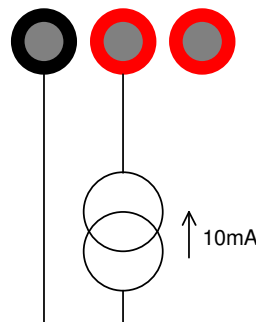

Calibrated Current Source

In the 'Calibration Menu' Window, use the **↑↓** keys to select '4-20mA Range' and then press the **↵** key to proceed to the '4-20mA Calibration Adjustment' Window. Use the **↑↓** keys to select each parameter in turn and press the **↵** key to enter their values:

4-20mA Range Calibration Adjustment:

1. Apply a 9-21mA current to channel 3
2. Enter details for standards used and then press OK to adjust calibration:

Current Applied

Standard S/N

Cancel

Press the **OK** (F4) key to start the calibration adjustment. Once started, the calibration adjustment process cannot be aborted.

5.3.8 Adjusting the RJC Sensor Calibration

Before you can use the RJC calibration adjustment feature you must first attach a calibrated thermocouple to one of the channels and configure the channel for use with this thermometer (see section 3.3.4). If you measure the ambient temperature with a calibrated PRT and use this as the “known” temperature for the calibration (see section 5.2.6 for details), you can reasonably use a good quality, uncalibrated thermocouple (the difference between ambient temperature and the reference junction will be very small, so any error will not be significant). If you use an uncalibrated thermocouple, make sure that you set the thermocouple ‘Conversion’ to the thermocouple type used:

Channel	Channel 1
Status	Enabled
Thermometer	Default Thermocouple
Type	Thermocouple
Conversion	Type J
Range	±115mV
Units	mV
Reference Junction	Internal
Samples/Reading	1
Readings in Stats	100

Single Multi Settings Instrument

From the ‘Calibration Menu’ Window, use the **↑****↓** keys to select ‘RJ Sensor’ and then press the **↵** key to proceed to the ‘RJ Sensor Calibration Adjustment’ Window. Use the **←****→** keys

to select channel 1 and then use the **↑****↓** keys to select each parameter in turn and press the **↵** key to enter their values:

RJ Sensor Calibration

Channel

1. Attach a calibrated thermocouple to the selected channel
2. Enter details for standards used and then press OK to adjust calibration:

Known Temperature	20.123000
Thermocouple Type	J - uncalibrated
Thermocouple S/N	not applicable
Additional Info.	wire has -6uV at 20C

Cancel
OK

Press the **OK** (F4) key to start the calibration adjustment. Once started, the calibration adjustment process cannot be aborted.

5.4 Exporting Calibration information

A calibration file containing the complete calibration history of the milliK in comma separated (CSV) form can be exported to a USB drive for transfer to a PC. The file can be imported into Excel™ or other suitable applications for viewing. To export the file connect a USB drive to the USB port on the rear of the milliK, go to the ‘Calibration Menu’ Window and press the **Export** (F3) key:

Calibration

Date: 08/04/2011

Name:

Company:

Location:

Room T/°C:

Cancel
Export
OK

For a milliK with serial number 11-P123, the file will be stored to the USB drive at
 :milliK\11-P123\Calibration\CalibrationFile.txt

6 Maintenance and Cleaning

Your milliK is a precision electronic instrument intended for indoor use in a laboratory, office or light industrial environment. Nonetheless, it has been designed to be as robust as is practical and will provide many years of service, provided it is properly maintained.

The screen, touch panel and case can be cleaned with a damp (not wet) cloth. Use either a proprietary screen cleaner (suitable for PC flat panel displays) or water and a little mild liquid soap on a lint-free cloth to clean your milliK. Dry the screen and touch panel immediately after cleaning with a lint-free cloth. Never use abrasive cleaners (such as 'cream' cleaners) or solvents on your milliK.

Miniature thermocouple plugs are of variable quality and lower quality versions can cause wear to the contacts in your milliK. If you feel that the thermocouple sockets on your milliK are becoming stiff, you can apply a small amount of contact lubricant (Electrolube CG53A is suitable: available internationally from Farnell Electronics via their website www.farnell.com under Farnell stock code 725602) onto the blades of a thermocouple plug and insert into the milliK thermocouple sockets several times.

7 Interfacing with milliK

The milliK is equipped with two RS232 ports and an Ethernet port that allow you to control its operation remotely including control via Isotech's "Cal Notepad" software (see section 8.6.3). The USB host port can be used to attach devices such as a mouse, keyboard or keypad to provide alternative means of driving the milliK using its user interface. You can attach a USB hub if you wish to use more than one USB device.

7.1 RS232 Interface

The milliK's RS232 interfaces can be used to control the milliK, perform calibration and diagnostic functions and to connect to and control one of Isotech's temperature sources.

You can connect and send commands to either or both COM ports. A typical arrangement would be to connect a PC to one COM port and control the instrument using software running on that PC. The milliK treats the two COM ports as separate input streams so that they do not interact with each other. If you were to connect separate PCs to the two COM ports then measurements made by software running on one PC would not affect measurement made by the other PC. There is of course only one measurement system that is being shared between the COM ports and the front panel operator interface, so any measurements made by one of these will slow down measurements made by any other. If you wish to control the milliK using the RS232 interface alone, do not press the **Start** (F4) key at the opening screen, the operator interface will then not request measurements, allowing faster measurements via the RS232 interface.

You can connect an Isotech temperature source to either of the COM port and use the milliK to control the source and make measurements under the control of the milliKs internal software. This provides a very effective and simple automatic calibration system. The milliK automatically detects when a COM port is connected to a temperature source allowing the ports to configure themselves and making the two RS232 ports totally interchangeable (the user can use either port interchangeably).

The command set uses the SCPI (Standard Commands for Programmable Instruments) protocol (see section 8.6.4 for details).

7.1.1 Establishing an RS232 Connection

The RS232 connectors are located on the rear of your milliK (see section 2.1). The connectors are 9-way (male) D-types configured as standard DTE devices:

Pin	Name	Function
1	CD	carrier detect (not connected)
2	RD	receive data
3	TD	transmit data
4	DTR	data terminal ready (fixed high)
5	SG	signal ground
6	DSR	data set ready (not connected)
7	RTS	request to send
8	CTS	clear to send
9	-	not used (not connected)
Shell	FG	frame ground (screen)

Connect your milliK to a PC using the null-modem RS232 cable supplied. If you wish to make your own cable, use the following arrangement:

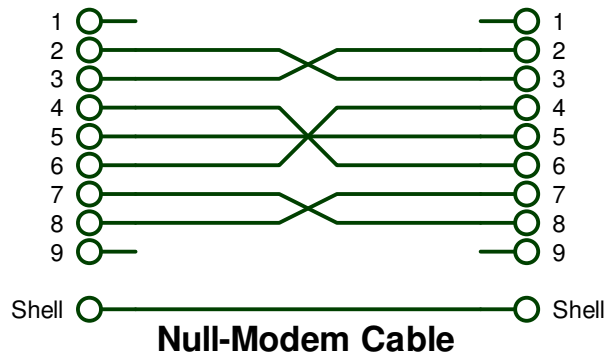

The data format for the RS232 interface is as follows:

Baud Rate	9,600
Start Bits	1
Stop Bits	1
Parity Bit	none

You can use Hyperterminal (or another terminal emulator) to communicate with the milliK via the RS232 connections. Hyperterminal is part of the standard Windows™ installation, usually located in the Accessories\Communications folder. If you have installed a minimum (laptop) or custom configuration (without this component) for your Windows™ operating system, you may need to install Hyperterminal from your original Windows™ media.

Start Hyperterminal to set up a new connection. Type in a name for the connection (such as milliK) and select an icon. In the next window, select the PC's COM port to which you have connected your milliK from the *Connect using* drop-down list and click OK. In the next window, enter the data format for the milliK's RS232 interface:

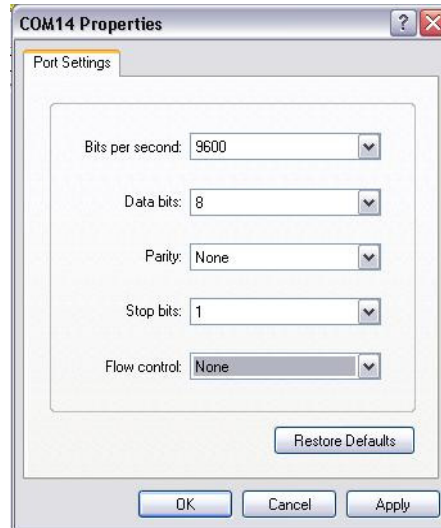

Click OK to open a Hyperterminal session with the milliK. Now save (using File|Save As) the Hyperterminal connection so that in future you only have to click on this icon to open an RS232 connection with your milliK.

Type **IDN?* into Hyperterminal (terminate the command by pressing the carriage return or Enter keys), the milliK should then respond with a string in the form:

Isothermal Technology, milliK,11-P234,1.0.7

This confirms that you have successfully established an RS232 connection with your milliK.

7.2 Ethernet Interface

You can connect your milliK to a local area network (Ethernet LAN) and control it from a remote PC. The milliK can be used with a fixed IP address or acquire its IP address from a DHCP server on the network. To select the whether a static (fixed) or dynamic (DHPC) address is used and set the address (static), press the **Instrument** key (F4), use the keys to select "Instrument Settings" and press the key to open the Instrument Settings Window:

Address Type	Static
IP Address	10
	2
	82
	44
Subnet Mask	255
	255
	255
	0
<input type="button" value="Cancel"/> <input type="button" value="OK"/>	

Use the \uparrow \downarrow keys to select each parameter and then press the $\left[\right]$ key to open a numeric window and enter the value. In the case of the “Address Type” parameter, the $\left[\right]$ key toggles between Static and Dynamic.

Connect the milliK’s Ethernet port (RJ45 connector on rear panel) to your LAN using a standard (non cross-over) patch cable. Then launch the “CE6 cerhost.exe” application (this Microsoft freeware application can be downloaded from <http://isotech.info/milliK>):



Click on “File” and then “Connect...” to establish connection with the milliK, a ‘Connect’ Window will then appear and after a few seconds it will show a list of available devices that includes the milliK (the milliK will be listed as “Tritonxx” where xx is a number assigned to the milliK in case you have more than one connected to the LAN):

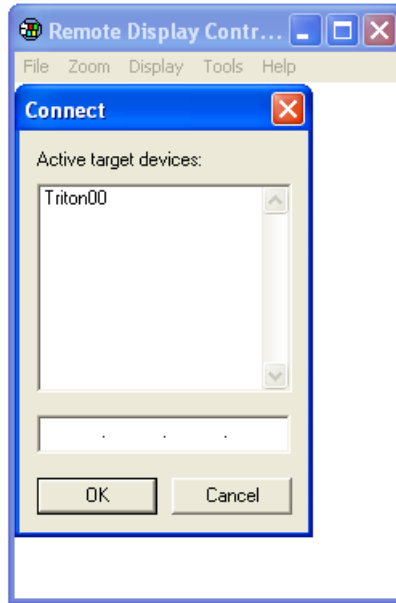

Click on the required device (“Triton00” in the above example) and then click OK, cerhost will then establish a connection and display the screen as it appears on your milliK:

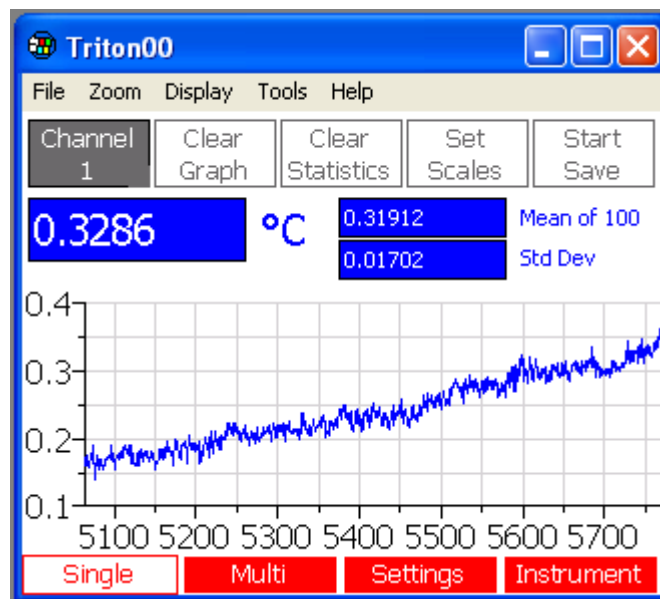

Click Tools|Config and select the “Whole Screen” radio button in the “Uppdate” area to ensure that the screen remains synchronised with your milliK. You can control your milliK using mouse clicks or the keyboard (function keys and up/down/left/right/enter keys) provided cerhost is the currently selected application on your PC.

8 SCPI Command Set

The command format and protocol used by the milliK is based on the SCPI (Standard Commands for Programmable Instruments) standard. This was developed to provide a consistent command language for all types of programmable instruments. The objective was to reduce the development time required by users of these instruments by providing a consistent programming environment through the use of defined messages, instrument responses and data formats. Further information on SCPI can be obtained from the SCPI Consortium (<http://www.scpiconsortium.org>).

8.1 Command Terminators

SCPI commands are ASCII (American Standard Code for Information Interchange) character strings and should be terminated with a Carriage Return character (ASCII character 13). Responses from the milliK are always terminated by a Carriage Return character.

8.2 SCPI Command Structure

Commands are arranged in a hierarchical tree, similar to directory trees used in PCs. SCPI uses a defined notation to represent the command tree structure. Each node in the tree structure is a command keyword with keywords being separated by colons (:). To simplify the description of the SCPI commands, the notation represents levels in the tree using horizontal indentations with the root node being the left most column. For example, the milliK includes the following command structure:

```

SENSe
  :FUNCTION
  :CHANNEL
  :RESistance
    :RANGe
    :RANGe?
READ?
CALibrate
  :VOLTage:GAIN
  :VOLTage:GAIN?

```

A valid command is formed by following the tree structure from a root node until a node is reached with no further nodes below it, for example in the above command tree we may use:

```
SENSe:RESistance:RANGe
```

Keywords can be shortened to the first four letters (or 3 if the last letter is a vowel). To indicate this, the notation uses upper-case to indicate required letters and lower-case to indicate optional letters (NB: all commands are case-insensitive). For example, valid forms of the above command include:

```
Sense:Resistance:Range  
SENS:RES:RANG  
Sense:resistance:RAnG
```

To shorten the commands, default (optional) keywords are enclosed in square brackets and may be omitted. For example, in the case of the command:

```
MEASure[:SCALar]:VOLTage:[DC]?
```

Valid forms of this command include:

```
MEAS:VOLT?  
MEASURE:SCALAR:VOLTAGE:DC?
```

8.3 SCPI Numeric Suffices

In order to support multiple input channels, commands can include numeric suffices. These are represented by a hash (#) in the command notation, for example:

```
MEASure:VOLTage<channel#>?
```

In order to measure the voltage on channel 2, the command used would be:

```
MEAS:VOLT2?
```

8.4 Parameters

If a command requires parameter(s), these follow the command and are separated from it by a space. If more than one parameter is required, each parameter is separated by a comma (.). For example, the command to measure resistance on channel 1 using a range up to 100 ohm at the normal 1mA sense current using a 4-wire technique is:

```
MEAS:RES1? 100,NORM,4
```

8.5 Units

Numeric parameters may optionally include units (if you omit units, the milliK assumes appropriate default units). The only units required for milliK are ohms (which are indicated by ‘R’, ‘r’, or OHM) and volts (indicated by ‘V’ or ‘v’).

The standard multiplying prefixes may also be used to indicate decimal multiples or fractions. For example, the following are all equivalent:

CAL:VOLT:OFFS1	2E3uV	
CAL:VOLT:OFFS1	2	(note: default units are mV)
CAL:VOLT:OFFS1	0.002V	

The following prefixes are available:

<i>prefix</i>	<i>name</i>	<i>factor</i>
U or u	micro	10^{-6}
M or m	milli	10^{-3} (cannot be used with ohms, see note below)
K or k	kilo	10^{+3}

Note: The SCPI standard does not permit the use of ‘M’ or ‘m’ as a prefix for ohms to indicate milli-ohms since the M or MA prefix is used to indicate mega-ohms.

8.6 Making Measurement Using SCPI Commands

The milliK’s measurement system can be controlled by SCPI commands from either of the RS232 ports. The software makes no distinction between commands received on either port and will process these in the order in which they are received. If a response is expected, it will always be sent to the port on which the initiating command was received.

There is no direct interference between measurements made using the front panel operator interface and measurements requested using SCPI commands. However, measurements take some time to complete so there may be a delay in responses to SCPI commands if measurements are being made via the front panel operator interface. To avoid unnecessary delays to responses to SCPI commands, you can stop all measurements requested via the front panel operator interface. To do this, restart the milliK but do not press the **Start** (F4) key in the opening window. The main application that provides the user interface will then not start and no measurements will be requested.

8.6.1 Measuring Resistance using SCPI Commands

In order to measure the resistance of a PRT, you need to:

- ⌋ select the measurement channel
- ⌋ set the milliK to measure resistance
- ⌋ select the measurement range
- ⌋ set the sense current (normal or root2 current)
- ⌋ select 3 or 4-wire measurement
- ⌋ make the measurement and collect the result

To use channel 1 to make a 4-wire resistance measurement on a 25.5Ω SPRT up to a maximum resistance of 80Ω using the normal (1mA) sense current, send the following command sequence:

```
SENS:CHAN 1
SENS:FUNC RES
SENS:WIR 4
SENS:RES:RANG 80
CURR NORM
READ?
```

The milliK will then report the measured resistance, for example “2.52506378E001”. Send **READ?** to make subsequent measurement using the same settings.

The following command performs the same measurement:

```
MEAS:RES1 80,NORM,4
```

8.6.2 Measuring Voltage using SCPI Commands

In order to measure the voltage from a thermocouple, you need to:

- ⌋ select the measurement channel
- ⌋ set the milliK to measure voltage
- ⌋ make the measurement

To measure the voltage from a thermocouple connected to channel 1, send the following command sequence:

```
SENS:CHAN 1
SENS:FUNC VOLT
READ?
```

The milliK will then report the measured voltage, for example “1.12999999E-007”. Send **READ?** to make subsequent measurement using the same settings.

The following command performs the same measurement:

MEAS:VOLT1?

8.6.3 Measuring Temperature using SCPI Commands

In order to measure temperature, you need to make one of the base unit measurements (resistance for PRTs/SPRTs/thermistors or voltage for thermocouples) and then convert this into a temperature using a conversion algorithm (for example ITS-90 for an SPRT). The data for the conversion temperature algorithms is stored in a database accessed from the operator interface. It would be very difficult to make this information available through SCPI commands so it is not possible to request a measurement in temperature units using SCPI commands. However, it is possible to set up measurement(s) using the operator interface and then to access the results using SCPI commands. To do this, simply setup your milliK to make the required measurement from the front panel (see section 3.1 for an example of how to do this) and then when the milliK is running and making the required measurement send the command:

MONITOR<channel#>? 4

Where <channel> is the number of the channel from which you require the measurement and 4 defines a four second timeout for the command. The milliK will then echo the measurement the next time a results is available for that channel. It will report the value and units, for example: “+9.87654321E+001,C”.

Where units	= R	(for ohms)
	=mV	(for milli-volts)
	= K	(for Kelvin)
	= C	(for °C)
	= F	(for °F)

If the milliK detects that the requested channel is not enabled, it will report “Channel Not Enabled”.

Isotech’s “Cal NotePad” software supports the milliK product (using the MON#? command) and can be downloaded from <http://isotech.info/milliK>

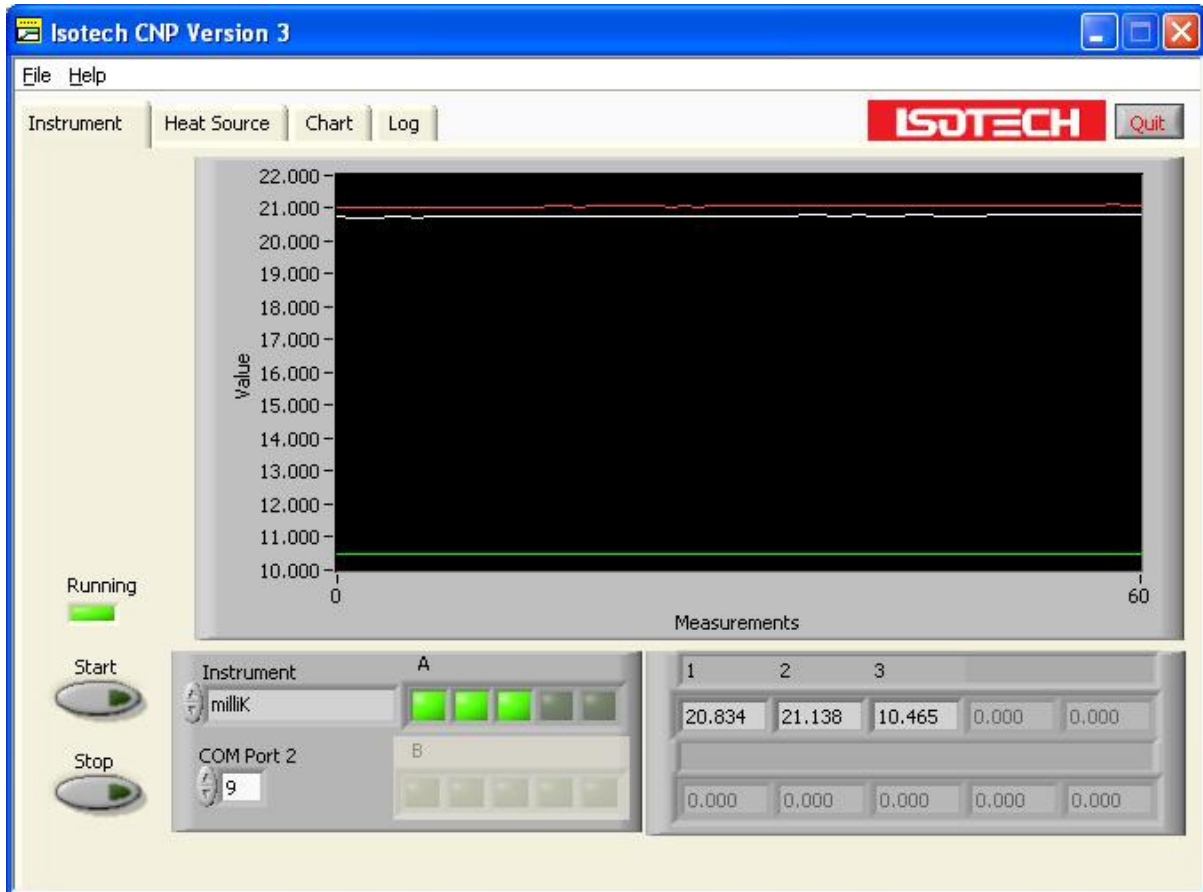

8.6.4 SCPI Commands

The milliK supports the following commands:

*IDN?

SENSE

:FUNCTION[:ON] <function>

:FUNCTION[:ON]?

:CHANNEL <channel>

:CHANNEL?

[:RESistance]

:RANGE[:UPPer] <range>

:RANGE[:UPPer]?

:WIRes <wires>

:WIRes?

:CURRENT <current>

:CURRENT?

INITiate[:IMMediate][:ALL]

FETCh[:SCALar]?

READ[:SCALar]?

MEASure[:SCALar]

:VOLTage[:DC]<channel#>?

:RESistance<channel#>? <resistance range>,<current>,<wires>

:CURRENT?

:RJC?

MONitor<channel#>? <timeout>

CALibrate

:UNLock <password>

:LOCK

:RESistance:GAIN <resistance range >,<current><gain>[,standard]

:RESistance:GAIN? <resistance range >,<current>

:VOLTage:OFFSet<channel#> <offset>

:VOLTage:OFFSet<channel#>?

:VOLTage:GAIN <gain>[,<standard>][,additional info]

:VOLTage:GAIN?

:CURRENT:GAIN <gain>[,standard]

:CURRENT:GAIN?

:RJC:OFFSet <offset>[,<TC type>][,<serial#>][,information]

:RJC:OFFSet?

:IDENTification <name>,<company>,<location>,<temperature>

:IDENTification?

:IDENTification:LAST?

:PASSword <old password,< password>,< password>

:VALid?

A detailed description of each command follows:

8.6.5 Command: *IDN?

Format: *IDN?

Reports information on the milliK in 4 comma separated fields:

- ⌋ manufacturer
- ⌋ model
- ⌋ serial number
- ⌋ firmware version

Example: for a milliK with serial number ITL12345 using software version 1.22.33, the milliK responds to *IDN? with:

Isothermal Technology,milliK,ITL12345,1.22.33

8.6.6 Command SENSE:FUNCTION[:ON]

Format: SENSE:FUNCTION[:ON] *<function>*

Selects the measurement function. The parameter *<function>* must be one of the following valid SCPI parameters:

- ⌋ RESistance
- ⌋ VOLTage[:DC]
- ⌋ CURRent

Example: to set the milliK to measure resistance, use: [SENS:FUNC RES](#)

8.6.7 Command SENSE:FUNCTION[:ON]?

Format: SENSE:FUNCTION?

Reports the present measurement function (RESISTANCE,VOLTAGE or CURRENT).

Example: a milliK set to measure voltage will respond to [SENS:FUNC?](#) with “VOLTAGE”.

8.6.8 Command SENSE:CHANnel

Format: SENSE:CHANnel *<channel>*

Selects the channel for the next measurement. The channels on the front panel are numbered 1 and 2. The 4-20mA input on the rear panel is numbered 3. The channel is not actually connected to the measurement system until a measurement is started using with either the INITiate or READ? commands.

Example: to select channel 2 for the next measurement, use: `SENS:CHAN 2`

8.6.9 Command SENSE:CHANnel?

Format: SENSE:CHANnel?

Reports the channel selected for the next measurement. The channels on the front panel are numbered 1 and 2. The 4-20mA input on the rear panel is numbered 3.

Example: a milliK set to measure channel 1 on the next measurement will respond to SENS:CHAN? with: “1”.

8.6.10 Command SENSE[:RESistance]:RANGe[:UPPer]

Format: SENSE[:RESistance]:RANGe[:UPPer] <range>

Sets the <range> for the next resistance measurement. The 3 resistance ranges available with the milliK are:

- ‡ *resistance range* = 0 - 115Ω
- ‡ *resistance range* = 0 - 460Ω
- ‡ *resistance range* = 0 - 500kΩ

The resistance range specified should be the highest resistance expected for the thermometer.

Example: to set the milliK to measure a PRT that has a resistance of 390Ω at its highest operating temperature, use: `SENS:RANG 390`

8.6.11 Command SENSE[:RESistance:]RANGe[:UPPer]?

Format: SENSE[:RESistance:]RANGe[:UPPer]?

Reports the range for the next resistance measurement.

Example: a milliK that has had its resistance range set to 390Ω using the command shown in section 8.6.10 would respond to the command: `SENS:RANG?` with: “460” since this is the most sensitive range that can accommodate the requested range.

8.6.12 Command SENSE:RESistance:WIRes

Format: SENSE:RESistance:WIRes <*wires*>

Determines whether the next resistance measurement will be made using 3 or 4-wire resistance measurement technique (see section 3.1.3 for details on 3 and 4-wire measurements). The parameter <*wires*> must be 3 or 4, otherwise the command will be ignored.

Example: to select 3-wire measurement for the next resistance measurement, use :

[SENS:RES:WIR 3.](#)

8.6.13 Command SENSE:RESistance:WIRes?

Format: SENSE:RESistance:WIRes?

Reports whether 3 or 4-wire measurement is selected for the next resistance measurement.

Example: a milliK that has been set to make a 4-wire resistance measurement will respond to the command: [SENS:RES:WIR?](#) with: "4".

8.6.14 Command SENSE:CURRent

Format: SENSE:CURRent <*current*>

Determines whether the normal (1mA) or root2 (1.4mA) current is used for the next resistance measurement on a PRT/SPRT. Changing the current to root2 allows the self heating effect to be determined for a PRT/SPRT (see section 3.1.2 for details). This command affects the sense current used to measure PRTs/SPRTs (115 Ω and 460 Ω ranges), it does not affect the sense current used to measured thermistors (fixed at 2 μ A). The current is not changed until a measurement is started using with either the INITiate or READ? commands. The parameter <*current*> may be NORMal or ROOT2, the command will be ignored if any other parameter is used.

Example: to set the sense current for the next resistance measurement to the normal current (1mA) use: [SENS:CURR NORM](#)

8.6.15 Command SENSE:CURRent?

Format: SENSE:CURRent?

Reports the current that will be used for the next resistance measurement.

Example a milliK that has been set to normal current and one of the PRT ranges (115 or 460Ω) will respond to the command: **SENS:CURR?** with: “1.00000E-003” (i.e. 1mA).

8.6.16 Command INITiate[:IMMediate][:ALL]

Format: INITiate[:IMMediate][:ALL]

Initiates a measurement using the conditions defined by previous SENSE commands. The measurement is made immediately, but not reported.

Example: to initiate a (voltage) measurement that has been defined with SENSE commands (such as **SENS:CHAN 1**, **SENS:FUNC volt**) use: **INIT**

8.6.17 Command FETCh[:SCALar]?

Format: FETCh[:SCALar]?

Reports the result of the last measurement made.

Example: a milliK that has made a measurement on channel 1 using the commands shown in the example in section 8.6.16 will respond to **FETC?** with a value in the form: “0.00154514”.

8.6.18 Command READ[:SCALar]?

Format: READ[:SCALar]?

Initiates and reports a measurement using the conditions defined by previous SENSE commands. This is equivalent to **INIT** followed by **FETCh?**

Example: a milliK that has been configured to make a voltage measurement using SENSE commands (such as **SENS:CHAN 1**, **SENS:FUNC volt**) will respond to **READ?** with a value in the form: “0.00154514”.

8.6.19 Command MEASure[:SCALar]:VOLTage[:DC]<channel#>?

Format: MEASure[:SCALar]:VOLTage[:DC]<channel#>?

Initiates and reports a voltage measurement on <channel#> (note that there is no gap between the command and the channel number as this command makes use of the numeric suffices feature of SCPI described in section 8.3). The reported value is in volts. This command is equivalent to `SENS:FUNC volt`, `SENS:CHAN <channel>`, and `READ?`

Example: to make a voltage measurement on channel 2 use: `MEAS:VOLT2?`

8.6.20 Command MEASure[:SCALar]:RESistance<channel#>

Format: `MEASure[:SCALar]:RESistance<channel#>? <range>,<current>,<wires>`

Initiates and reports a resistance measurement on <channel#> using resistance <range> with sense <current> and 3 or 4 wires measurement defined by <wires> (note that there is no gap between the command and the channel number as this command makes use of the numeric suffices feature of SCPI described in section 8.3). The reported value is in ohms. This command is equivalent to `SENS:FUNC RES`, `SENS:CHAN <channel>`, `SENS:RES:RANG <range>`, `SENS:WIR <wires>` and `READ?`

Example: to measure the resistance of a PRT on channel 1 that has a maximum operating resistance of 390Ω with root2 sense current using a 4 wire technique, use:

`MEAS:RES1? 390,root2,4`

8.6.21 Command MEASure[:SCALar]:CURRent?

Format: `MEASure[:SCALar]:CURRent?`

Initiates and reports a current measurement on channel 3 (4-20mA input on rear panel). The reported value is in milli-amps. This command is equivalent to `SENS:FUNC CURR`, `SENS:CHAN 3`, and `READ?`

Example: to make a current measurement on channel 3 use: `MEAS:CURR?`

8.6.22 Command MEASure[:SCALar]:RJC?

Format: `MEASure[:SCALar]:RJC? <channel>`

Initiates and reports a measurement of the reference junction temperature (used with thermocouples for reference junction compensation) of the specified <channel>. The

reported value is in °C. If the specified channel does not exist, the milliK returns “channel not found”.

Example: to measure the temperature of channel 1’s thermocouple reference junction use:

[MEAS:RJC? 1](#)

8.6.23 Command **MONitor<channel#>?**

Format: **MONitor<channel#>? <timeout>**

Reports the next measurement (including units) made on <channel#> within the specified <timeout>, in seconds. If a measurement is not made within the specified timeout, the milliK reports “Timeout”. If the milliK detects that the channel is not enabled, it reports “Channel Not Enabled”. The milliK reports the value followed by the units (separated by a comma):

Where units	= R	(for ohms)
	=mV	(for milli-volts)
	= K	(for Kelvin)
	= C	(for °C)
	= F	(for °F)

Example: if channel 2 is configured to measure temperature in °C, a typical response to [MON2? 5](#) would be “1.23456,C”.

8.6.24 Command **CALibrate:UNLock**

Format: **CALibrate:UNLock <password>**

Unlocks the milliK to allow calibration adjustment. The milliK always powers up in the locked state. Calibration can be re-locked by cycling the power to the milliK or using [CAL:LOCK](#) (see section 8.6.25).

Example: to unlock (enable) the calibration adjustment on a milliK with the default password (“1234”), use: [CAL:UNL 1234](#)

8.6.25 Command **CALibrate:LOCK**

Format: **CALibrate:LOCK**

Locks the milliK to prevent calibration adjustment.

Example: to lock the calibration of a milliK after adjustment, use: [CAL:LOCK](#)

8.6.26 Command CALibrate:RESistance:GAIN

Format: CALibrate:RESistance:GAIN *<range>*,*<current>*,*<gain>*,[*<standard>*]

Sets the resistance measurement *<gain>* for the specified resistance *<range>* and *<current>* with the option to specify the *<standard>* used. Gains outside the range 0.99 to 1.01 are ignored. The optional *<standard>* parameter is a string that is stored in the calibration database file (which can be exported to a USB flash drive: see section 5.4) and can be used to identify the calibration standard used. Typically it would be used to identify the serial number of the standard. The *<current>* can be specified as either NORMAL or ROOT2.

Example: for a milliK that has been found to require a resistance gain of 1.001234 for the resistance range 0-460Ω with normal (1mA) sense current by using a resistance standard with serial number xyz1956, the gain can be set using:

or [CAL:RES:GAIN 460,NORM,1.001234,SN_xyz1956](#)
[CAL:RES:GAIN 460,NORM,1.001234](#)

8.6.27 Command CALibrate:RESistance:GAIN?

Format: CALibrate:RESistance:GAIN? *<range>*,*<current>*

Reports the resistance measurement gain for the specified resistance *<range>* and *<current>*. The *<current>* can be specified as either NORMAL or ROOT2. The milliK will accept gains for the thermistor range (500kΩ) with root2 current, but this is not used (thermistors measurements are always made with a 2μA sense current)

Example: to read the resistance gain for the 115Ω range with normal (1mA) sense current use:

[CAL:RES:GAIN? 115,NORM](#)

8.6.28 Command CALibrate:VOLTage:OFFSet<channel#>

Format: CALibrate:VOLTage:OFFSet<channel#> *<offset>*

Sets the *<offset>* added to voltage measurements made on *<channel#>*. The default units for the offset are milli-volts. Offsets outside the range ±10μV are ignored.

Example: to apply (add) an offset of 2 μ V (0.002mV) to voltage measurements made on channel 1 you can use:

or `CAL:VOLT:OFFS1 0.002`
`CAL:VOLT:OFFS1 2uV`

8.6.29 Command CALibrate:VOLTage:OFFset<channel>?

Format: CALibrate:VOLTage:OFFSet<channel#>?

Reports the <offset> added to voltage measurements made on <channel> in volts.

Example: a milliK with a +1 μ V offset added to voltage measurement made on channel 1 will respond to `CAL:VOLT:OFFS1?` with: “0.00000100”

8.6.30 Command CALibrate:VOLTage:GAIN

Format: CALibrate:VOLTage:GAIN <gain>[,<standard>][,<additional info>]

Sets the <gain> used for voltage measurements. Gains outside the range 0.98 to 1.02 are ignored. The optional <standard> and <additional info> parameters are strings that are stored in the calibration database file (which can be exported to a USB flash drive: see section 5.4) to provide information about this calibration. Typically <standard> would be used to identify the serial number of the voltage standard used. The <additional info> parameter is provided so store an additional serial number in case two standards are used (precise low voltages are often realised by using a calibrated reference resistor together with a current source).

Example: for a milliK that has been found to require a voltage gain of 1.001234 by using a standard resistor with serial number xyz1956 and a current source with serial number abc9960, the gain can be set using:

or `CAL:VOLT:GAIN 1.001234,SN_xyz1956,SN_abc9960`
`CAL:VOLT:GAIN 1.001234`

8.6.31 Command CALibrate:VOLTage:GAIN?

Format: CALibrate:VOLTage:GAIN?

Reports the voltage measurement gain.

Example: a milliK with a voltage gain set to 1.001234 will respond to [CAL:VOLT:GAIN?](#) with “1.001234”

8.6.32 Command CALibrate:CURRent:GAIN

Format: CALibrate:CURRent:GAIN <gain>[,<standard>]

Sets the <gain> used for current measurements. Gains outside the range 0.98 to 1.02 are ignored. The optional <standard> parameter is a string that is stored in the calibration database file (which can be exported to a USB flash drive: see section 5.4) to provide information about this calibration. Typically it would be used to identify the serial number of the standard used. Example: for a milliK that has been found to require a current gain of 1.001234 by using a reference standard with serial number xyz1956, the gain can be set using:

or [CAL:CURR:GAIN 1.001234,SN_xyz1956](#)
[CAL:VOLT:GAIN 1.001234](#)

8.6.33 Command CALibrate:CURRent:GAIN?

Format: CALibrate:CURRent:GAIN?

Reports the current measurement gain.

Example: a milliK with a current gain set to 1.001234 will respond to [CAL:CURR:GAIN?](#) with “1.001234”

8.6.34 Command CALibrate:RJC:OFFSet

Format: CALibrate:RJC:OFFSet <offset>[,<TC type>][,<serial#>][,<info>]

Sets the <offset> (in °C) added to measurements of thermocouple reference junction temperatures. Offsets outside the range $\pm 10^{\circ}\text{C}$ are ignored. The optional parameters are strings that are stored in the calibration database file (which can be exported to a USB flash drive: see section 5.4) to provide information about this calibration. Typically these would be used to store information on the thermocouple type used in the calibration, the serial number of this thermocouple and additional information such as the serial number of the temperature source used.

Example: to apply (add) an offset of 0.05°C to the reference junction measurements determine by using a type N thermocouple with serial number xyz1956 and in a liquid bath with serial number abc9960 use:

or [CAL:RJC:OFFS 0.05,type_N,xyz1956,abc9960](#)
[CAL:RJC:OFFS 0.05](#)

8.6.35 Command CALibrate:RJC:OFFSet?

Format: CALibrate:RJC:OFFSet?

Reports the *<offset>* (in °C) added to measurements made by the reference junction sensor used for reference junction compensation.

Example: a milliK with +0.1°C added to reference junction temperature measurements will respond to [CAL:RJC:OFFS?](#) with: “0.1”

8.6.36 Command CALibrate:IDENtification

Format: CALibrate:IDENtification <name>,<company>,<location>,<temperature>

Sets identification information used to “stamp” any calibrations that are made after this command (until the milliK is restarted). This information would typically be used to store information on the calibration technician, the calibration organisation and environment.

Example: for calibrations made by John Smith at Isotech at Isotech’s primary standards laboratory operating at 20°C ± 1°C, use: [CAL:IDEN JSmith,Isotech,Primary_Lab,19-20C](#)

8.6.37 Command CALibrate:IDENtification?

Format: CALibrate:IDENtification?

Reports the calibration information that will be used to “stamp” subsequent calibrations.

Example: a milliK that has been set to stamp calibrations using the information shown in section 8.6.36 would respond to [CAL:IDEN?](#) with: “JSmith,Isotech,Primary_Lab,19-20C”

8.6.38 Command CALibrate:IDENtification:LAST?

Format: CALibrate:IDENtification:LAST?

Reports the calibration information for the last calibration made to the milliK.

Example: If the milliK had been calibrated by Joe Bloggs of Metrosol in their secondary laboratory at 20°C ±2°C and had not had any calibration adjustment applied since it might respond to **CAL:IDEN?** with: “JBloggs,Metrosol,Main_Lab,18-22C”

8.6.39 Command CALibrate:PASSword

Format: CALibrate:PASSword *<old password>*,*<password>*,*<password>*

Changes the password used to lock (protect) the calibration of the milliK’s measurement system. This is initially set to “1234”, but should be changed before using the milliK for any critical or traceable measurement or calibration work. The new password must be at least 4 characters in length and must be typed in identically twice in order to effect the change.

Example: to change the password from 1234 to ABCD use: **CAL:PASS 1234,ABCD,ABCD**

8.6.40 Command CALibrate:VALid?

Format: CALibrate:VALid?

Reports whether the calibration information loaded from the milliK’s database is valid. If it is not valid it will provide an error code that should be reported to Isotech when requesting technical support.

Example: a correctly calibrated milliK will respond to **CAL:VAL?** with: “Calibration Okay”

9 Specification

<u>Inputs</u>	Channel 1 & 2: Channel 3 (rear panel)	SPRT/PRT/thermistor/Thermocouple 4-20mA current loop with optional 24V loop supply
<u>Ranges</u>	SPRTs: PRTs: Thermistors: Thermocouples: 4-20mA:	0-115Ω 0-460Ω 0-500kΩ ±115mV 0-30mA
<u>Units</u>		°C, °F, K, Ω, mV, mA
<u>Accuracy</u>	SPRTs/PRTs: Thermistors: Thermocouples: 4-20mA:	Initial 5ppm 50ppm 1μV + 0.002% of reading ±0.01% Over 1 year 7ppm 150ppm 1μV + 0.006% of reading ±0.02%
<u>Temperature Accuracy</u>	SPRTs/PRTs (at 0°C): (over full range): Thermistors: Thermocouples (ice-point reference): Type B @ 1000°C: Type E @ 600°C: Type J @ 600°C: Type K @ 600°C: Type L @ 600°C: Type N @ 600°C: Type R @ 1000°C: Type S @ 1000°C: Type T @ 200°C: Au-Pt @ 600°C: Thermocouples (internal reference junction compensation): Type B @ 1000°C: Type E @ 600°C: Type J @ 600°C: Type K @ 600°C: Type L @ 600°C: Type N @ 600°C: Type R @ 1000°C: Type S @ 1000°C: Type T @ 200°C: Au-Pt @ 600°C:	Initial 3mK 5mK 50ppm ±0.12°C ±0.02°C ±0.03°C ±0.04°C ±0.03°C ±0.04°C ±0.09°C ±0.10°C ±0.02°C ±0.06°C ±0.14°C ±0.05°C ±0.05°C ±0.06°C ±0.05°C ±0.06°C ±0.12°C ±0.14°C ±0.03°C ±0.08°C ±0.12°C ±0.10°C ±0.12°C ±0.23°C ±0.25°C ±0.23°C ±0.19°C ±0.21°C ±0.24°C ±0.18°C ±0.15°C
<u>Measurement Time</u>	PRTs (4-wire): (3-wire): Thermistors: Thermocouples (ice point): (internal RJC): (external RJC):	0.4s 0.7s 0.4s 0.4s 0.7s 1.0s
<u>Resolution</u>	Resistance (PRTs): (Thermistors): Voltage: Current: Temperature:	0.00001Ω 0.001Ω 0.00001mV 0.001mA 0.0001°
<u>Temperature Conversions</u>	PRTs: Thermocouples: Thermistors:	IEC60751(2008), Callendar-van Dusen, ITS90 IEC584-1 1995 (B,E,J,K,N,R,S,T), L, Au-Pt Steinhart-Hart, polynomial
<u>Sensor Currents</u>	SPRTs/PRTs: Thermistors:	1mA and 1.428mA ±0.4% (reversing) 2μA (reversing)

<u>Keep-Warm Current</u>	SPRTs/PRTs: 1mA and 1.428mA
<u>Cable Length</u>	30m (<10Ω per core and <10nF between cores)
<u>Input Connectors</u>	SPRTs/PRTs: Lemo EPG.1B.306.HLN 6-pin gold plated contacts Thermocouples: Miniature Thermocouple socket (ASTM E 1684-05) 4-20mA: 4mm sockets
<u>Interfaces</u>	10/100MBit Ethernet (RJ46 socket) USB (2.0) host 2 x RS262 (9-pin D-type plug, 9600 Baud)
<u>Display</u>	89mm / 3.5" QVGA (320 x 240) colour TFT LCD with long-life LED backlight
<u>Operating Conditions</u>	Operating: 0-40°C / 32-113°F, 0-95% humidity Full Specification: 15-30°C / 50-85 °F, 10-90% humidity
<u>Power</u>	90-264V (RMS), 47-63Hz (universal), 6W maximum
<u>Size</u>	255mm x 255mm x 114mm / 10" x 10" x 4.5" (W x D x H)
<u>Weight</u>	2.25kg / 5lb

Note: The temperature accuracy figures for thermocouples depend on the slope of the V-T curve for the selected thermocouple type and on the measured temperature (since the slope varies with temperature). Additionally, if reference junction compensation (internal or external) is used rather than an ice-point reference, the total accuracy also depends on the slope of the V-T curve at the reference junction temperature (typically around 20°C). The temperature accuracy figures for thermocouples presented in the table above are at representative temperatures for the thermocouple type.

The curves below show how the temperature accuracy varies with measured temperature (both initial and 1-year) for all the thermocouple types supported by the milliK when it is used with either an ice-point reference (for highest accuracy) or internal reference junction compensation (the least accurate, but most convenient method).

To determine the temperature accuracy for external reference junction compensation (see section 26), calculate the accuracy to which you are measuring the reference junction temperature (depends on the accuracy of the PRT used, the accuracy of the milliK measuring the PRT and the temperature gradient between the reference junction and the temperature sensor) and then interpolate between the “ice point reference” and “internal RJC” curves using the fact that the RJC sensor accuracy is ±0.1°C (initially) / ±0.2°C (1-year).

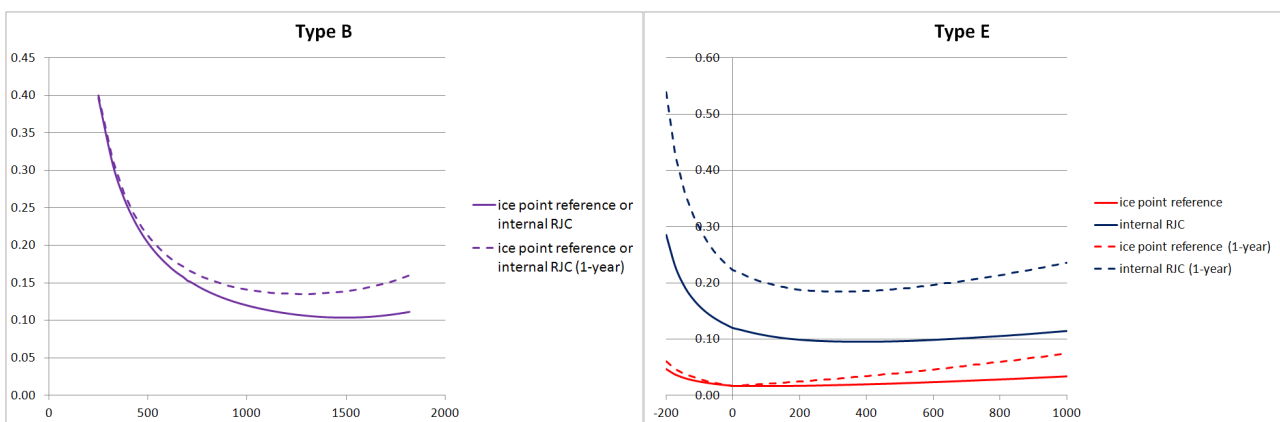

x-axis = measured temperature in °C, y-axis = temperature accuracy on °C

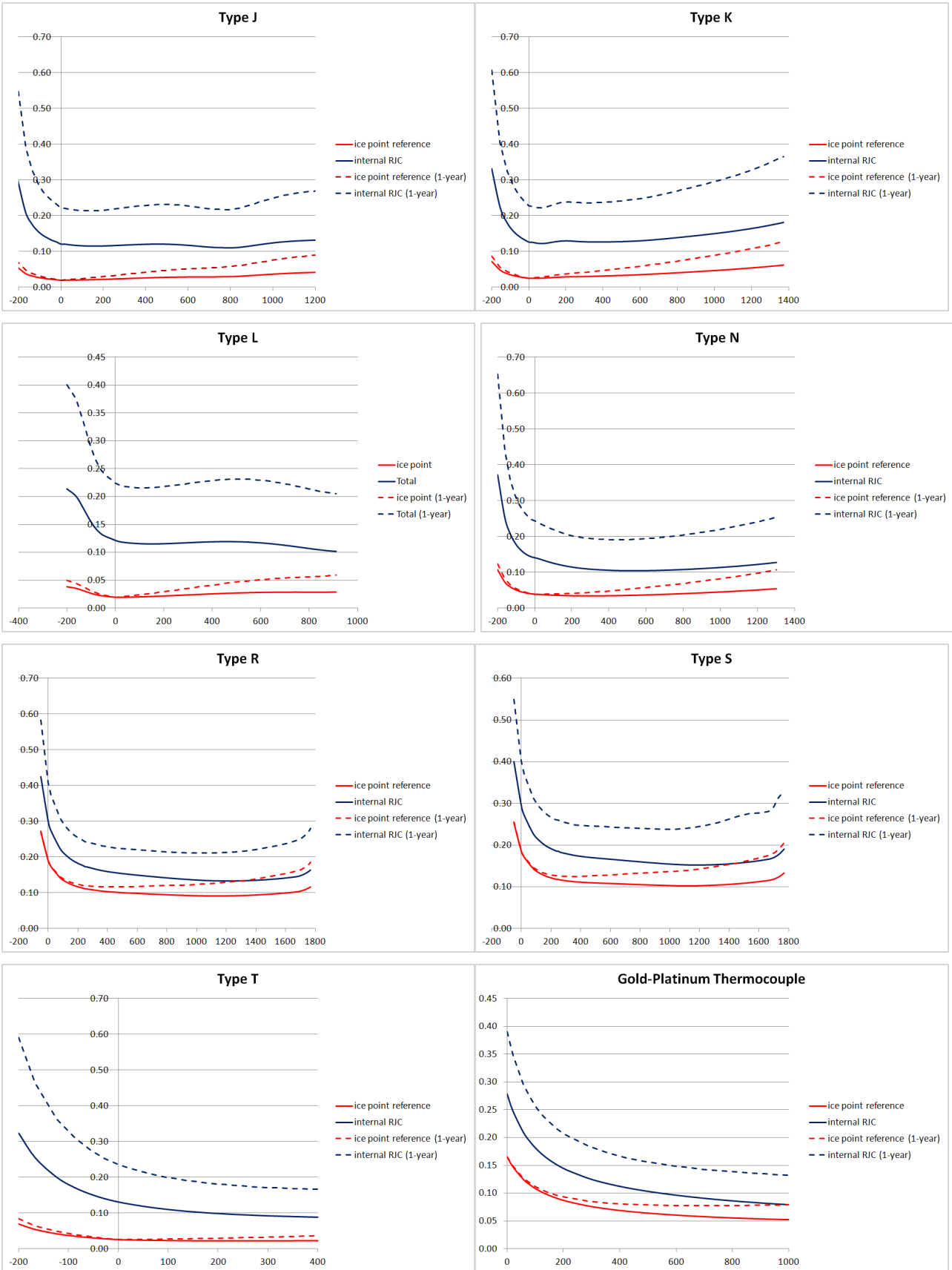

x-axis = measured temperature in °C, y-axis = temperature accuracy on °C

10 Approvals

The milliK has been verified as complying with the regulatory requirements of the EU and FCC for electromagnetic compatibility and safety (EU only).

10.1 CE Declaration



European Community Electromagnetic Compatibility Directive (89/336)
European Community Low Voltage Directive (93/68)

The milliK Precision Thermometer manufactured by Isothermal Technology Limited of Pine Grove, Southport, Merseyside, PR9 9AG, United Kingdom conforms to the requirements of the European Community Electromagnetic Compatibility Directive (89/336) and of the European Community Low Voltage Directive (93/68).

10.2 FCC Statement

This equipment has been tested and found to comply with the limits for a Class A digital device, pursuant to part 15 of the FCC Rules. These limits are designed to provide reasonable protection against harmful interference when the equipment is operated in a commercial environment. This equipment generates and can radiate radio frequency energy and, if not installed and used in accordance with the instruction manual, may cause harmful interference to radio communications. Operation of this equipment in a residential area may cause harmful interference, in which case the user will be required to correct the interference at his own expense. Changes or modifications to this equipment not expressly approved by Isothermal Technology could degrade EMC performance and void the user's authority to operate the equipment.

10.3 Standards Applied

The following standards have been applied in assessing compatibility with the requirements for CE marking and for FCC compliance:

Conducted Emissions	EN61326:2006 & CFR47:2009
Radiated Emissions	EN61326:2006 & CFR47:2009
Conducted Immunity	EN61326:2006
Radiated Immunity	EN61326:2006
Electrical Fast Transients	EN61326:2006
Electrostatic Discharge	EN61326:2006
Surge	EN61326:2006
Voltage Dips & Interruptions	EN61326:2006
Harmonic Currents	EN61000-3-2:2006
Flicker	EN61000-3-3:2008
Electrical Safety	EN61010-1:2001

11 Revision History

Change Note	Date	Manual Issue
Initial release	April 2011	1.01
CN11008	17/06/2011	1.02
CN12002	07/02/2012	1.03
CN 12013	16/05/2012	1.04
CN 12014	30/05/2012	1.05
CN 12029	08/11/2012	1.06
CN 13013	21/05/2013	1.07
CN 13021	11/10/2013	1.08
CN14016	16/05/2014	1.09
CN15007	23/10/2015	1.10